

European Technical Assessment **ETA 24/0670** of 26/08/2024

I General Part

Technical Assessment Body issuing the ETA and designated according to Article 29 of the Regulation (EU) No 305/2011:

Trade name of the construction product

Product family to which the construction product belongs

Manufacturer

Manufacturing plant

This European Technical Assessment contains

This European Technical Assessment is issued in accordance with regulation (EU) No 305/2011, on the basis of

Eurofins Expert Services Oy

**Sewatek Fire Collars
Sewatek Special Fire Collars
Sewatek Multi Penetration
Sewatek Fire Wrap**

Fire stopping and Fire Sealing Products

**Sewatek Oy Sepäntie 4
FI-07230 Askola Finland**

**Sewatek Oy Sepäntie 4
FI-07230 Askola Finland**

40 pages including 3 Annex which form an integral part of this assessment

**European Assessment Document
EAD 350454-00-1104, edition September
2017**

Translations of this European Technical Assessment in other languages shall fully correspond to the original issued document and should be identified as such.

Communication of this European Technical Assessment, including transmission by electronic means, shall be in full excepted the confidential Annex(es) referred to above. However, partial reproduction may be made, with the written consent of the issuing Technical Assessment Body. Any partial reproduction has to be identified as such.

This European Technical Assessment may be withdrawn by the issuing Technical Assessment Body, pursuant to information by the Commission according to Article 25 Paragraph 3 of Regulation (EU) No 305/2011.

Table of Contents

I General Part	1
II Specific Part	4
1 Technical description of the products	4
1.1 Sewatek Fire Collars	4
1.2 Sewatek Special Fire Collars	4
1.3 Sewatek Multi Penetrations	4
1.4 Sewatek Fire Wrap	4
1.5 Installation.....	4
2 Specification of the intended uses in accordance with the applicable European Assessment Document, EAD	4
2.1 Intended uses	4
2.2 Use category.....	5
2.3 Execution of construction works	5
3 Performance of the product and references to the methods used for its assessment	6
3.1 Safety in case of fire, BWR 2.....	6
3.1.1 Reaction to fire.....	6
3.1.2 Resistance to fire	6
3.2 Hygiene, health and environment, BWR 3.....	6
3.2.1 Dangerous substances	6
3.3 Protection against noise, BWR 5	7
3.3.1 Airborne sound insulation of walls and floors	7
3.4 General aspects.....	7
3.4.1 Aspects of durability	7
Durability has been assessed according to document EOTA TR 24 Clause 4.2.5.....	7
According to EAD 350454-00-1104 clause 1.2 penetration seal is categorized as Type Y2.....	7
3.4.2 Identification	7
4 Assessment and verification of constancy of performance (hereinafter AVCP) system applied, with reference to its legal base	7
5 Technical details necessary for the implementation of the AVCP system, as provided for in the applicable EAD.	7
Annex 1 - Products	8
Low-Density Rigid Wall	8
1a - Sewatek Fire Collars.....	8
1b - Sewatek Special Fire Collars.....	10

1c - Sewatek Multi Penetration	11
1d - Sewatek Fire Wrap	13
High-Density Rigid Floor	15
2a - Sewatek Fire Collars	15
2b - Sewatek Special Fire Collars	18
2c - Sewatek Multi Penetration	19
2d - Sewatek Fire Wrap	22
Massive Wood (CLT or LVL) Wall	25
3a - Sewatek Fire Collars	25
3b - Sewatek Multi Penetration	27
3c - Sewatek Fire Wrap	28
Massive Wood Floor	29
4a - Sewatek Multi Penetration	29
4b - Sewatek Fire Wrap	30
Flexible Wall	31
5a - Sewatek Fire Collars	31
5b - Sewatek Multi Penetration seals	32
5c - Sewatek Fire Wrap	33
Annex 2 – Insulation	34
Wall structure	34
LI – Local and Interrupted	34
LS – Local and Sustained	34
CI – Continuous and Interrupted	35
CS – Continuous and Sustained	35
Floor structure	36
LI – Local and Interrupted	36
LS – Local and Sustained	37
CI – Continuous and Interrupted	38
CS – Continuous and Sustained	39
Annex 3 – The principle of measurement	40
Cluster Layout	40
In-Line Layout	40

II Specific Part

1 Technical description of the products

1.1 Sewatek Fire Collars

Fire collars are fire stopping steel collars with intumescent band inside.

1.2 Sewatek Special Fire Collars

Special fire collars are fire stopping steel collars with intumescent band inside. The products are used when changing materials of pipes from metal to plastic.

1.3 Sewatek Multi Penetrations

Multi penetrations are fire penetration seals with plastic cover, intumescent band inside the cover and seals.

1.4 Sewatek Fire Wrap

Wraps are fire stopping products with intumescent band packed in plastic cover.

1.5 Installation

Products can be mounted as a single unit or as a group. Penetrations are classified as a group of penetration seals (clusters) or a single penetration seal. Fire resistance class of a cluster is allowed to extend to an equivalent single penetration seal but not vice versa. Minimum distances between penetration devices are given in Annex 1.

2 Specification of the intended uses in accordance with the applicable European Assessment Document, EAD

2.1 Intended uses

The Penetration seals is intended to be used temporarily or permanent reinstate the fire resistance performance of rigid concrete wall or roof/floor constructions or CLT/LVL (Cross laminated timber/Laminated veneer lumber) wall/floor or flexible walls which are provided with apertures which are penetrated by various cables or metallic or plastic pipes. The minimum thickness for unprotected CLT/LVL wooden construction is 100 mm. The thickness of the wood can be lower if the wood construction has a non-flammable surface (e.g. gypsum) and the thickness of the construction is at least 100 mm.

Penetrations can be mounted either into

- min 95 mm, 100 mm or 150 mm thick low density rigid wall ($650 \pm 200 \text{ kg/m}^3$)
- min 95 mm thick standardized flexible wall
- min 150 mm, 200 mm or 240 mm thick high-density rigid floor ($\geq 850 \text{ kg/m}^3$)
- min 100 mm thick CLT/LVL wall or floor (density min. 450 kg/m^3).

The provisions made in this European Technical Assessment are based on an assumed intended working life of 25 years provided that the product is subjected to appropriate use and maintenance¹.

2.2 Use category

The penetration seal is intended for internal use also at temperatures below 0 °C and can therefore according to EAD 350454-00-1104 clause 1.2 be categorized as Type Y2. The product also meets requirements of types Z1 and Z2.

This European Technical Assessment is based on the assumption that all plans needed have been made correctly according to the regulations valid on the building site.

2.3 Execution of construction works

It is the responsibility of the manufacturer to ensure that proper information for the use of the Sewatek penetration seal is enclosed to each delivery, including general guidance on the basis of this ETA and the specific installation instructions and construction details. With regard to the assumed working life regular maintenance is necessary. The manufacturer shall provide with written documents which contain descriptions about type and frequency of the maintenance.

The completed building (the works) shall comply with the building regulations (regulations on the works) applicable in the Member States in which the building is to be constructed. The procedures foreseen in the Member State for demonstrating compliance with the building regulations shall also be followed by the entity held responsible for this act. An ETA for Sewatek penetration seal does not amend this process in any way.

¹This means that it is expected that when this working life has elapsed, the real working life may be, in normal use conditions, considerably longer without major degradation affecting the essential requirements of the works. The indications given as to the working life of Sewatek penetration system cannot be interpreted as a guarantee given by the producer or the assessment body. They should only be regarded as a means for the specifiers to choose the appropriate criteria for penetration seals in relation to the expected, economically reasonable working life of the works.

3 Performance of the product and references to the methods used for its assessment

Table 1. Basic requirements for construction works and essential characteristics

Basic requirement and essential characteristics	Performance
BWR 1. Mechanical resistance and stability	
Not relevant	
BWR 2. Safety in case of fire	
Reaction to fire of materials and components, EN 13501-1	No performance assessed
Resistance to fire, EN 13501-2	EI 30 – EI 120 (Annex 1)
BWR 3. Hygiene, health and the environment	
Air permeability	No performance assessed
Water permeability	No performance assessed
Content, emission and/or release of dangerous substances	No performance assessed
BWR 4. Safety and accessibility in use	
Mechanical resistance and stability	No performance assessed
Resistance to impact / movement	No performance assessed
Adhesion	No performance assessed
Durability	Clause 3.4.1
BWR 5. Protection against noise	
Airborne sound insulation	Multi: Clause 3.3.1. Other products: No performance assessed
BWR 6. Energy economy and heat retention	No performance assessed
Thermal properties	No performance assessed
Water vapour permeability	No performance assessed
General aspects	
Aspects of durability	Clause 3.4.1

3.1 Safety in case of fire, BWR 2

3.1.1 Reaction to fire

The reaction to fire has not been assessed.

3.1.2 Resistance to fire

For floors and walls, classification with regard to resistance to fire is based on full scale testing as specified in EN 13501-2. Fire resistance classes are presented in Annex 1.

3.2 Hygiene, health and environment, BWR 3

3.2.1 Dangerous substances

In addition to the specific clauses relating to dangerous substances contained in this European Technical Assessment, there may be other requirements applicable to the products falling within its scope (e.g.

transposed European legislation and national laws, regulations and administrative provisions). In order to meet the provisions of the EU Construction Products Directive, these requirements need also to be complied with, when and where they apply.

3.3 Protection against noise, BWR 5

3.3.1 Airborne sound insulation of walls and floors

Multi Penetration: Influence of single penetration seal on R_w highest is 0-2 dB, when concrete thickness ≥ 200 mm.

- R: EN ISO 10140-1:2016, EN ISO 10140-2:2010
- R_w : EN ISO 717-1:2013

3.4 General aspects

3.4.1 Aspects of durability

Durability has been assessed according to document EOTA TR 24 Clause 4.2.5. According to EAD 350454-00-1104 clause 1.2 penetration seal is categorized as Type Y2.

3.4.2 Identification

The components and materials are identified as being of a generic type or giving a brand name, as described in Annex 1 and specified in the manufacturer's Contents of delivery list. The component under a given brand name may be changed by the manufacturer to another with corresponding performance.

4 Assessment and verification of constancy of performance (hereinafter AVCP) system applied, with reference to its legal base

EC Decision for AVCP is System 1. 1999/0454/EC

5 Technical details necessary for the implementation of the AVCP system, as provided for in the applicable EAD.

Technical details necessary for the implementation of the AVCP system are laid down in the control plan deposited at Eurofins Expert Services Oy.

Espoo on August 26, 2024
by Eurofins Expert Services Oy

Katja Vahtikari
Manager, Construction Certification

Heli Välimäki
Senior Expert

ANNEX 1

Annex 1 - Products

Low-Density Rigid Wall

1a - Sewatek Fire Collars

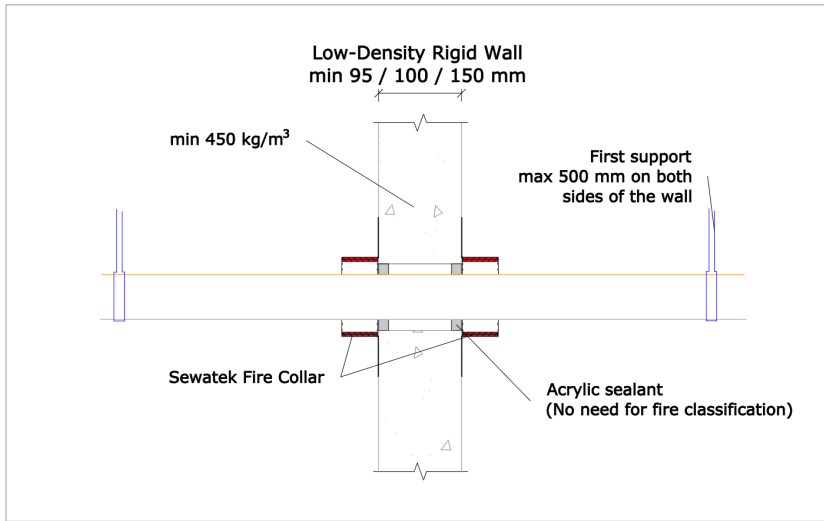

Fire Collar	a ₁ (mm)
C 16-32	5
C 25-50	5
C 50-80	7
C 75-110	7
C 110-130	7
C 125-160	12

(Casting or drill hole)

Table 1a. Sewatek Fire Collars mounted in 95 mm or 100 mm or 150 mm thick low-density rigid wall

Insulation markings (See Annex 2)	Markings (See Annex 3)
LI – Local and Interrupted CI – Continuous and Interrupted CS – Continuous and Sustained sw – Stone wool insulation cr – Cellular rubber insulation	e _n – Pipe wall thickness a ₁ – Thickness of the pipe closure device a ₂ – Distance between pipe closure devices When tested as a single, a ₂ – distance is 100 mm ("-" in the table)
sw insulation thickness	
- 20 mm (Pipes < 54 mm)	
- 30 mm (Pipes ≥ 54 mm)	

Type of the pipe	Penetration seal	Insulation (thickness / length)	a ₂ [mm]	Fire resistance class
Composite pipes				
Mounted into/onto low-density rigid wall of 95 mm				
∅ ≤ 75 mm, e _n ≤ 8,0 mm	C 50-80	CI (sw 30 mm / -)	-	EI 60 - U/C
Mounted into/onto low-density rigid wall of 100 mm				
∅ ≤ 25 mm, e _n ≤ 3,0 mm	C 16-32	not required	58	EI 120 - U/C
∅ ≤ 40 mm, e _n ≤ 4,0 mm	C 25-50	not required	50	EI 90 - U/C
Plastic PEX-pipes				
Mounted into/onto low-density rigid wall of 100 mm				
PEX ∅ ≤ 22/34 mm, e _n ≤ 3,0 mm	C 25-50	not required	38	EI 120 - U/C
PEX ∅ ≤ 28/54 mm, e _n ≤ 3,0/1,0 mm	C 50-80	not required	57	EI 60 - U/C
PEX ∅ ≤ 40 mm, e _n ≤ 4,0 mm	C 25-50	not required	60	EI 90 - U/C
PEX bundle ∅ ≤ 45 mm - singular PEX / cover pipe ∅ ≤ 40 mm	C 25-50	not required	60	EI 90 - U/C

ANNEX 1

Type of the pipe	Penetration seal	Insulation (thickness / length)	a ₂ [mm]	Fire resistance class
PP (EN 1451-1), PVC (EN 13476) and multilayer sewer pipes				
<i>Mounted into/onto low-density rigid wall of 100 mm</i>				
PP Ø ≤ 110 mm, e _n ≤ 6,5 mm	C 75-110	not required	-	EI 60 - U/C
PP Ø ≤ 110 mm, e _n ≤ 4,2 mm	C 75-110	not required	60	EI 60 - U/C
PP Ø ≤ 110 mm, e _n ≤ 8,0 (on muff 4,0 + 4,0 mm)	C 110-130	not required	-	EI 90 - U/C
PVC Ø ≤ 110 mm, e _n ≤ 3,4 mm	C 75-110	not required	30	EI 90 - U/C
<i>Mounted into/onto low-density rigid wall of 150 mm</i>				
Ø ≤ 160 mm, e _n ≤ 6,5 mm <ul style="list-style-type: none"> • PP-pipes (EN 1451-1) • Geberit: Silent (dB20, Pro, PP) • Pipelife: Master 3+ • Polo-Kal: NG/XS, 3S • Rehau: Raupiano Plus • Uponor: HTP, Decibel • Wavin: AS+, SiTech+ 	C 125-160	not required	30	EI 90 - U/C
Sewer pipes with lining				
<i>Mounted into/onto low-density rigid wall of 95 mm</i>				
PVC Ø ≤ 110 mm, e _n ≤ 3,4 mm + lining (Boldan, Brawoliner, Trelleborg)	C 75-110	not required	30	EI 90 – U/C
PP Ø ≤ 110 mm, e _n ≤ 3,4 mm + lining (Boldan, Brawoliner, Trelleborg)	C 75-110	not required	30	EI 90 – U/C
Cables				
<i>Mounted into/onto low-density rigid wall of 100 mm</i>				
Cable conduit Ø ≤ 25,0 mm e _n ≤ 1,5 mm, - cable bundle Ø ≤ 22 mm - singular cable Ø ≤ 13 mm	C 16-32	not required	58	EI 120
Cable conduit Ø ≤ 40,0 mm e _n ≤ 1,5 mm - cable bundle Ø ≤ 37 mm - singular cable Ø ≤ 17 mm	C 25-50	not required	38	EI 120
Cable bundle Ø ≤ 66 mm - singular cable Ø ≤ 25 mm	C 50-80	not required	30	EI 90

Low-Density Rigid Wall installations

1b - Sewatek Special Fire Collars

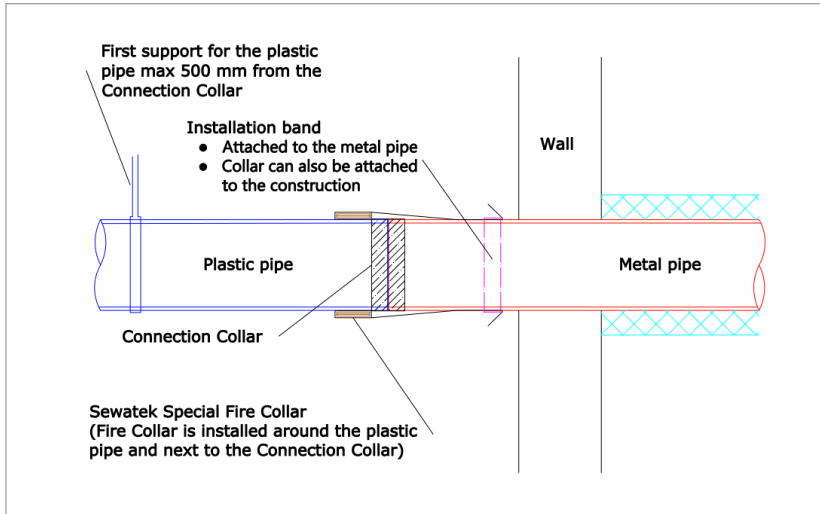

Special Fire Collar	a ₁ (mm)
C 50x	7
C 75x	7
C 90x	7
C 110x	7
C 130x	7
C 160x	12

Table 1b. Sewatek Special Fire Collars tested with 150 mm thick low-density rigid wall

Insulation markings (See Annex 2)	Markings (See Annex 3)
LI – Local and Interrupted CI – Continuous and Interrupted CS – Continuous and Sustained sw – Stone wool insulation cr – Cellular rubber insulation	e _n – Pipe wall thickness a ₁ – Thickness of the pipe closure device a ₂ – Distance between pipe closure devices When tested as a single, a ₂ – distance is 100 mm ("-" in the table)
sw insulation thickness - 20 mm (Pipes < 54 mm) - 30 mm (Pipes ≥ 54 mm)	

Type of the pipe	Penetration seal	Insulation (thickness / length)	a ₂ [mm]	Fire resistance class
Sewer pipes, material changes to plastic				
<i>Tested with low-density rigid wall of 150 mm</i>				
Ø ≤ GR 110 (DN100), e _n ≤ 4,0 mm Ø ≤ PP 110 (EN 1451-1), e _n ≤ 3,8 mm	C 110x	GR: CI (sw 30 mm / -) PP: not required	-	EI 90 - U/U

Low-Density Rigid Wall

1c - Sewatek Multi Penetration

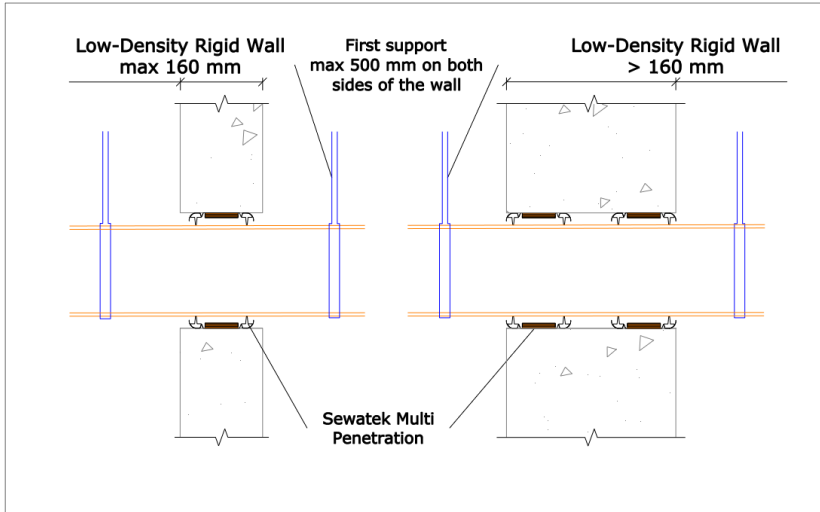

Multi	Max penetrating pipe / bundle	a ₁ (mm)
D80	50	15
D105	75	15
D140	110	15

(Casting or drill hole)

Table 1c. Sewatek Multi Penetration seals D80, D105, D140 mounted in 100 mm or 150 mm thick low density rigid wall

Insulation markings (See Annex 2)	Markings (See Annex 3)
LI – Local and Interrupted CI – Continuous and Interrupted CS – Continuous and Sustained sw – Stone wool insulation cr – Cellular rubber insulation	e _n – Pipe wall thickness a ₁ – Thickness of pipe closure device a ₂ – Distance between pipe closure devices When tested as a single, a ₂ – distance is 100 mm ("-" in the table)

sw insulation thickness
 - 20 mm (Pipes < 54 mm)
 - 30 mm (Pipes ≥ 54 mm)

Type of the pipe	Insulation (thickness / length)	a ₂ [mm]	Fire resistance class
Steel and cast-iron pipes			
<i>Mounted into the low-density rigid wall of 100 mm</i>			
∅ < 110 mm, e _n ≤ 4,0 mm	CI (sw 30 mm / -)	-	EI 120 - U/C
PP (Polypropylene) and multilayer sewer pipes			
<i>Mounted into the low-density rigid wall of 100 mm</i>			
∅ ≤ 110, e _n ≤ 6,5 mm • PP-pipes (EN 1451-1) • Geberit: Silent (dB20, Pro, PP) • Pipelife: Master 3+ • Polo-Kal: NG/XS, 3S • Rehau: Raupiano Plus • Uponor: HTP, Decibel • Wavin: AS+, SiTech+	not required	-	EI 120 - U/C
∅ ≤ 110, e _n ≤ 6,0 mm • PP-pipes (EN 1451-1) • Geberit: Silent (dB20, Pro, PP) • Pipelife: Master 3+ • Polo-Kal: NG/XS, 3S • Rehau: Raupiano Plus • Uponor: HTP, Decibel • Wavin: AS+, SiTech+	not required	30	EI 60 U/C

ANNEX 1

Mounted into the low-density rigid wall of 150 mm			
$\varnothing \leq 110$, $e_n \leq 3,6$ mm	not required	60	EI 120 - U/C
PP and multilayer sewer pipes (mounted on muff OR / AND without plastic cover and gaskets)			
Mounted into the low-density rigid wall of 100 mm			
$\varnothing \leq 110$, $e_n \leq 6,5$ mm <ul style="list-style-type: none"> • PP-pipes (EN 1451-1) • Geberit: Silent (dB20, Pro, PP) • Pipelife: Master 3+ • Polo-Kal: NG/XS, 3S • Rehau: Raupiano Plus • Uponor: HTP, Decibel • Wavin: AS+, SiTech+ 	not required	30	EI 90 - U/C
Pex pipes			
Mounted into the low-density rigid wall of 100 mm			
Pex bundle $\varnothing \leq 100$ mm - singular pipe $\varnothing \leq 40/54$ mm, $e_n \leq 2,5 - 4,2$ mm	not required	-	EI 90 - U/C
Cables			
Mounted into the low-density rigid wall of 100 mm			
Cable conduit $\varnothing \leq 110$ mm (plastic) - cable bundle $\varnothing \leq 100$ mm - singular cable $\varnothing \leq 25$ mm	not required	-	EI 60

Low Density Rigid Wall

1d - Sewatek Fire Wrap

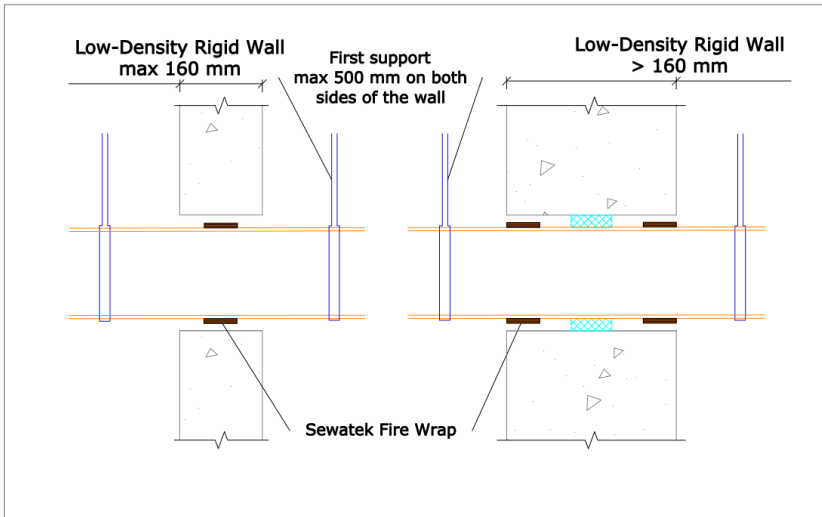

Fire Wrap	a ₁ (mm)
W 50	7
W 75	7
W 110	7

(Casting or drill hole)

Table 1d. Sewatek Fire Wrap mounted in 100 mm or 150 mm thick low density rigid wall	
Insulation markings (See Annex 2)	Markings (See Annex 3)
LI – Local and Interrupted CI – Continuous and Interrupted CS – Continuous and Sustained sw – Stone wool insulation cr – Cellular rubber insulation	e _n – Pipe wall thickness a ₁ – Thickness of the pipe closure device a ₂ – Distance between pipe closure devices When tested as a single, a ₂ – distance is 100 mm ("-" in the table)
sw insulation thickness	
- 20 mm (Pipes < 54 mm)	
- 30 mm (Pipes ≥ 54 mm)	

** Sewatek fire wrap on both sides of the wall

Type of the pipe	Insulation (thickness / length)	a ₂ [mm]	Fire resistance class
Steel and cast-iron pipes			
<i>Mounted into the low-density rigid wall of 100 mm</i>			
∅ < 110 mm, e _n ≤ 4,0 mm	CI (sw 30 mm / -)	-	EI 120 - U/C
PP (Polypropylene) and multilayer sewer pipes			
<i>Mounted into the low-density rigid wall of 100 mm</i>			
∅ ≤ 110, e _n ≤ 10,6 mm (on muff 5,3 + 5,3 mm) ** • PP-pipes (EN 1451-1) • Geberit: Silent (dB20, Pro, PP) • Pipelife: Master 3+ • Polo-Kal: NG/XS, 3S • Rehau: Raupiano Plus • Uponor: HTP, Decibel • Wavin: AS+, SiTech+	not required	-	EI 120 U/C
∅ ≤ 110, e _n ≤ 6,5 mm • PP-pipes (EN 1451-1) • Geberit: Silent (dB20, Pro, PP) • Pipelife: Master 3+ • Polo-Kal: NG/XS, 3S • Rehau: Raupiano Plus • Uponor: HTP, Decibel • Wavin: AS+, SiTech+	not required	30	EI 90 U/C

ANNEX 1

<i>Mounted into the low-density rigid wall of 150 mm</i>			
PP (EN 1451-1) $\varnothing \leq 110$, $e_n \leq 3,6$ mm	not required	60	EI 120 - U/C
Pex pipes			
<i>Mounted into the low-density rigid wall of 100 mm</i>			
Pex bundle $\varnothing \leq 100$ mm - singular pipe $\varnothing \leq 40/54$, $e_n \leq 2,5 - 4,2$ mm	not required	-	EI 90 - U/C
Cables			
<i>Mounted into the low-density rigid wall of 100 mm</i>			
Cable conduit $\varnothing \leq 110$ mm (plastic) - cable bundle $\varnothing \leq 100$ mm - singular cable $\varnothing \leq 25$ mm	not required	-	EI 60

High-Density Rigid Floor

2a - Sewatek Fire Collars

Installation way 2a-1 (Casting or drill hole)

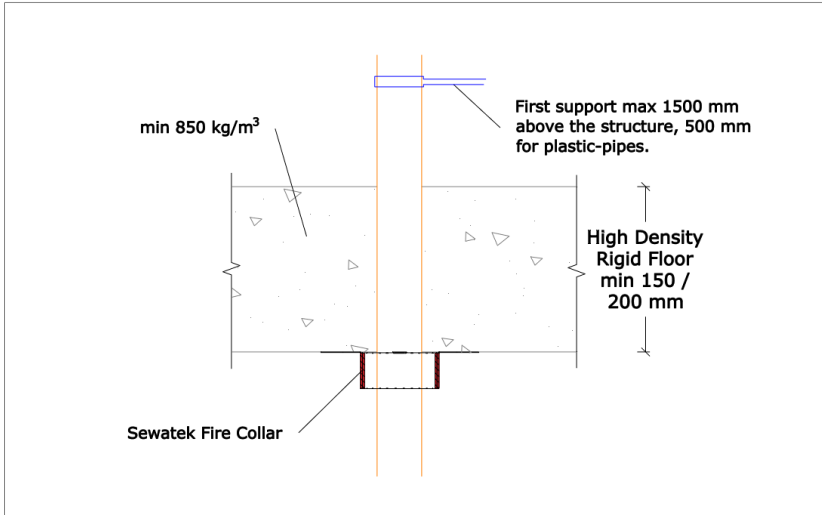

Fire Collar	a ₁ (mm)
C 16-32	5
C 25-50	5
C 50-80	7
C 75-110	7
C 110-130	7
C 125-160	12

Installation way 2a-2 (Casting or drill hole)

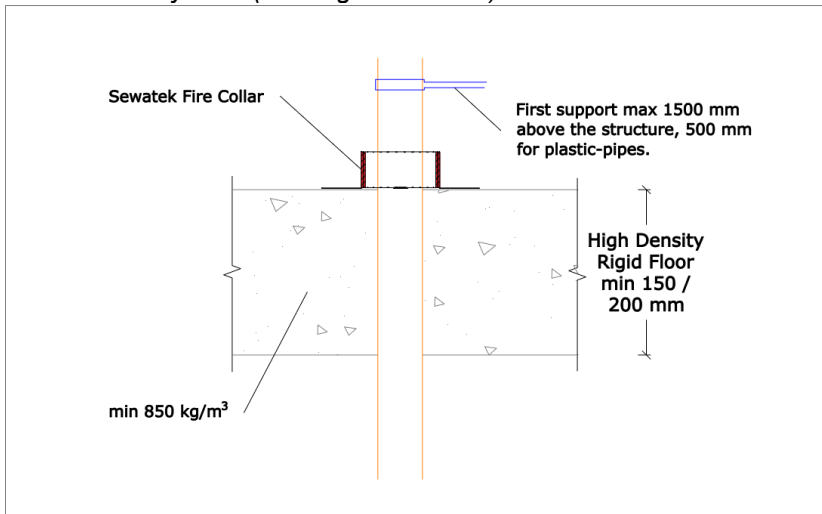

Installation way 2a-3 (Casting or drill hole)

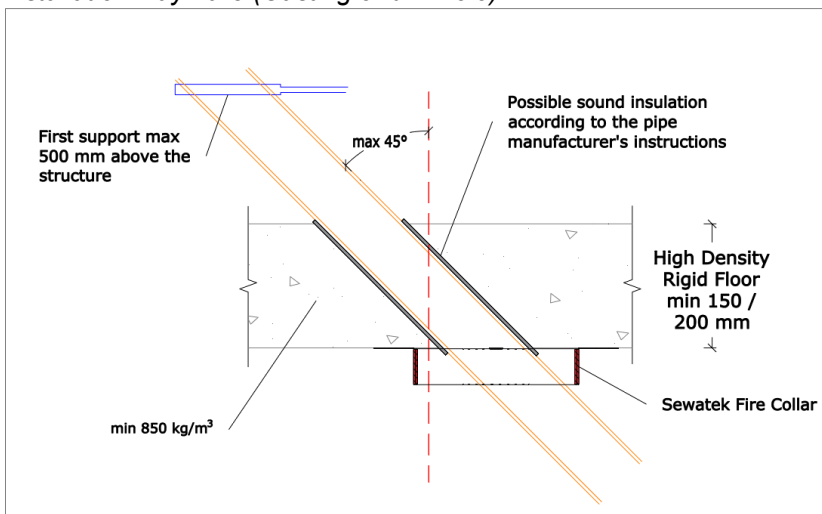

ANNEX 1

Table 2a. Sewatek Fire Collars mounted in 150 mm or 200 mm thick high-density rigid floor.	
Insulation markings (See Annex 2)	Markings (See Annex 3)
LI – Local and Interrupted CI – Continuous and Interrupted CS – Continuous and Sustained sw – Stone wool insulation cr – Cellular rubber insulation	<i>sw insulation thickness</i> - 20 mm (Pipes < 54 mm) - 30 mm (Pipes ≥ 54 mm)
	e _n – Pipe wall thickness a ₁ – Thickness of the pipe closure device a ₂ – Distance between pipe closure devices When tested as a single, a ₂ -distance is 100 mm ("-" in the table)

Type of the pipe	Penetration seal	Insulation (thickness / length)	a ₂ [mm]	Fire resistance class
<i>Installation below the construction – (Installation way 2a-1)</i>				
Composite pipes				
<i>Mounted into/onto high-density rigid floor of 200 mm</i>				
∅ ≤ 16 mm, e _n ≤ 2,5 mm	C 16-32	not required	78	EI 120 - U/C
∅ ≤ 40 mm, e _n ≤ 4,5 mm	C 25-50	not required	58	EI 120 - U/C
<i>Mounted into/onto high-density rigid floor of 150 mm</i>				
∅ ≤ 32 mm, e _n ≤ 3,0 mm	C+ 80-110	CS (cr 13 mm / -)	20	EI 120 - U/C
∅ ≤ 16 mm, e _n ≤ 2,0 mm and ∅ ≤ 25 mm, e _n ≤ 2,5 mm inside ∅ 90 mm plastic pipe filled with PU foam	C+ 80-110	not required	100	EI 120 - U/C
PEX-pipes				
<i>Mounted into/onto high-density rigid floor of 200 mm</i>				
PEX ∅ ≤ 28/54 mm, e _n ≤ 4,0 / 3,0 mm	C 50-80	not required	-	EI 120 - U/C
CoolFit				
<i>Mounted into/onto high-density rigid floor of 150 mm</i>				
∅ ≤ 110/160 mm, e _n ≤ 10 mm, PUR 25 mm	C 125-160	not required	-	EI 90 - U/C
PP, PVC and multilayer sewer pipes				
<i>Mounted into/onto high-density rigid floor of 200 mm</i>				
PP (1451-1) ∅ ≤ 110 mm, e _n ≤ 8,0 (4,0 + 4,0 on muff)	C 110-125	not required	-	EI 120 - U/C
<i>Mounted into/onto high-density rigid floor of 150 mm</i>				
∅ ≤ 160 mm, e _n ≤ 6,0 mm <ul style="list-style-type: none"> • PP-pipes (EN 1451-1) • Geberit: Silent (dB20, Pro, PP) • Pipelife: Master 3+ • Polo-Kal: NG/XS, 3S • Rehau: Raupiano Plus • Uponor: HTP, Decibel • Wavin: AS+, SiTech+ 	C 125-160	not required	-	EI 120 - U/U
∅ ≤ 110 mm, e _n ≤ 5,3 mm <ul style="list-style-type: none"> • PP-pipes (EN 1451-1) • Geberit: Silent (dB20, Pro, PP) • Pipelife: Master 3+ • Polo-Kal: NG/XS, 3S • Rehau: Raupiano Plus • Uponor: HTP, Decibel • Wavin: AS+, SiTech+ 	C 75-110	not required Sound insulation (PE ≤ 3,5 mm) can penetrate the collar	30	EI 90 - U/U

ANNEX 1

Type of the pipe	Penetration seal	Insulation (thickness / length)	a ₂ [mm]	Fire resistance class
$\varnothing \leq 110$ mm, $e_n \leq 10,6$ mm (5,3 + 5,3 on muff) <ul style="list-style-type: none"> • PP-pipes (EN 1451-1) • Geberit: Silent (dB20, Pro, PP) • Pipelife: Master 3+ • Polo-Kal: NG/XS, 3S • Rehau: Raupiano Plus • Uponor: HTP, Decibel • Wavin: AS+, SiTech+ 	C 110-130	CI (sw 30 mm / -) Sound insulation (PE 9,0 mm) can penetrate the collar	-	EI 60 - U/U
PVC (EN 13476) $e_n 3,4$ mm ≤ 110	C 75-110	CI (sw 30 mm / -)	-	EI 120 U/U
Sewer pipes with lining				
<i>Mounted into/onto high-density rigid floor of 150 mm</i>				
PVC, PP $\varnothing \leq 110$ mm, $e_n \leq 3,4$ mm + lining (Boldan, Brawoliner, Trelleborg)	C 75-110	CI (sw 30 mm / -)	-	EI 120 – U/U
PP $\varnothing \leq 110$ mm, $e_n \leq 3,4$ mm + lining (Boldan, Brawoliner, Trelleborg)	C 75-110	not required	-	EI 120 – U/C
PP and multilayer sewer pipes				
<i>Installation on the top of the construction - (Installation way 2a-2)</i>				
$\varnothing \leq 110$ mm, $e_n \leq 5,3$ mm <ul style="list-style-type: none"> • PP-pipes (EN 1451-1) • Geberit: Silent (dB20, Pro, PP) • Pipelife: Master 3+ • Polo-Kal: NG/XS, 3S • Rehau: Raupiano Plus • Uponor: HTP, Decibel • Wavin: AS+, SiTech+ 	C 75-110	not required	30	EI 60 - U/C
<i>Installation in an angle between 90° and 45° - (Installation way 2a-3)</i>				
$\varnothing \leq 110$ mm, $e_n \leq 4,5$ mm <ul style="list-style-type: none"> • PP-pipes (EN 1451-1) • Geberit: Silent (dB20, Pro, PP) • Pipelife: Master 3+ • Polo-Kal: NG/XS, 3S • Rehau: Raupiano Plus • Uponor: HTP, Decibel • Wavin: AS+, SiTech+ 	C 125-160	not required	-	EI 120 - U/C
<i>Installation in a hole max 90 mm bigger than the penetrating pipe (Tested as a part of customized product)</i>				
PP (EN 1451-1) $\varnothing \leq 110$ mm, $e_n \leq 3,8$ mm, Uponor Decibel	C+ 80-110	not required	20	EI 120 - U/U

High-Density Rigid Floor

2b - Sewatek Special Fire Collars

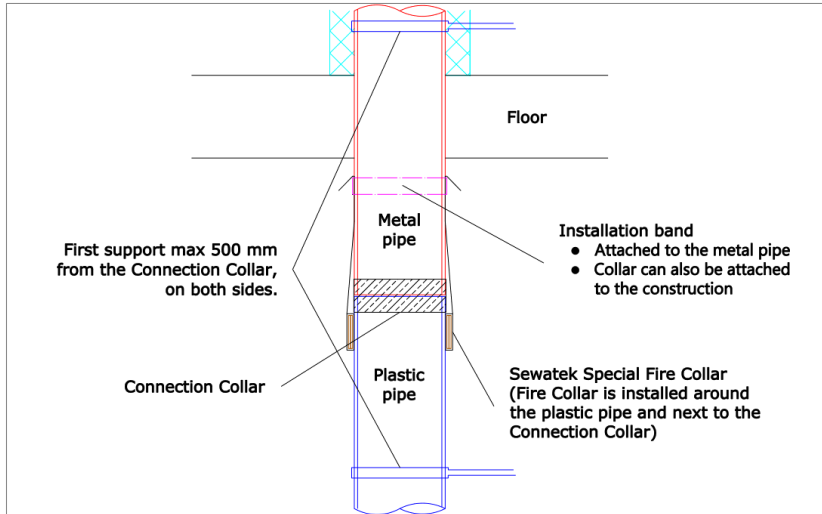

Special Fire Collar	a ₁ (mm)
C 50x	7
C 75x	7
C 90x	7
C 110x	7
C 130x	7
C 160x	12

Table 2b. Sewatek Special Fire Collars tested with **150 mm thick high-density rigid floor**

Insulation markings (See Annex 2)	Markings (See Annex 3)
LI – Local and Interrupted CI – Continuous and Interrupted CS – Continuous and Sustained sw – Stone wool insulation cr – Cellular rubber insulation	e _n – Pipe wall thickness a ₁ – Thickness of the pipe closure device a ₂ – Distance between pipe closure devices When tested as a single, a ₂ – distance is 100 mm ("-" in the table)
sw insulation thickness - 20 mm (Pipes < 54 mm) - 30 mm (Pipes ≥ 54 mm)	

Type of the pipe	Penetration seal	Insulation (thickness / length)	a ₂ [mm]	Fire resistance class
Sewer pipes, material changes from metal to plastic (PP: EN 1451-1)				
GR Ø ≤ 110 mm (DN100), e _n ≤ 4,0 mm PP Ø ≤ 110, e _n ≤ 3,8 mm	C 110x	Cast iron: CI (sw 30 mm / -) PP: not required	-	EI 120 - U/U
GR Ø ≤ 160 mm (DN150), e _n ≤ 5,0 mm PP Ø ≤ 160, e _n ≤ 5,4 mm	C 160x	Cast iron: LI (sw 30 / 500 mm) PP: not required	-	EI 90 - U/C
Stainless steel (RST) Ø ≤ 110 mm, e _n ≤ 1,2 mm PP Ø ≤ 110, e _n ≤ 3,8 mm	C 110x	RST: LI (sw 30 / 350 mm) PP: not required	-	EI 120 U/U

High-Density Rigid Floor

2c - Sewatek Multi Penetration

Installation way 2c-1 (Casting or drill hole)

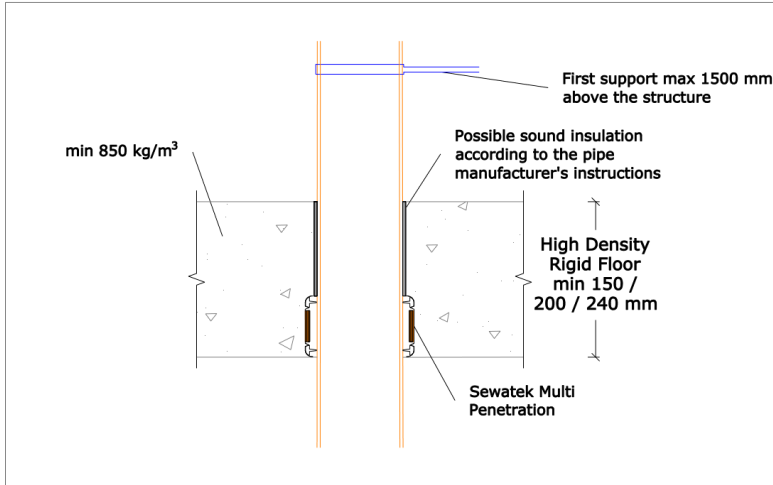

Multi	Max penetrating pipe / bundle	a ₁ [mm]
D80	50	15
D105	75	15
D140	110	15

Installation way 2c-2 (Casting or drill hole)

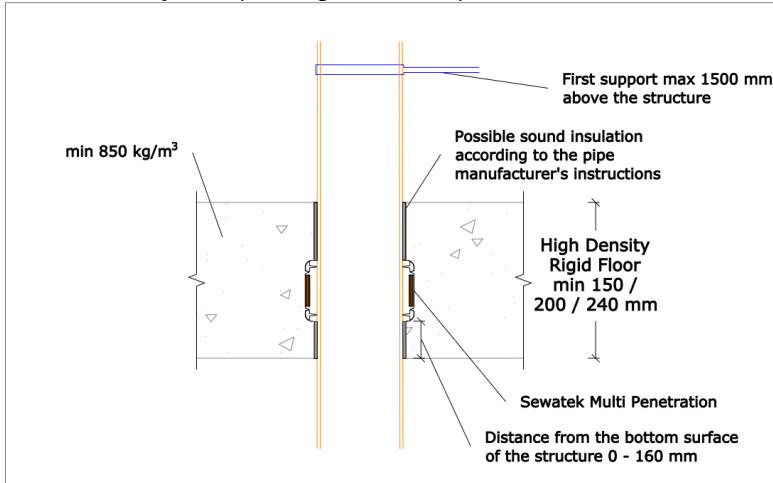

Installation way 2c-3 (Casting or drill hole)

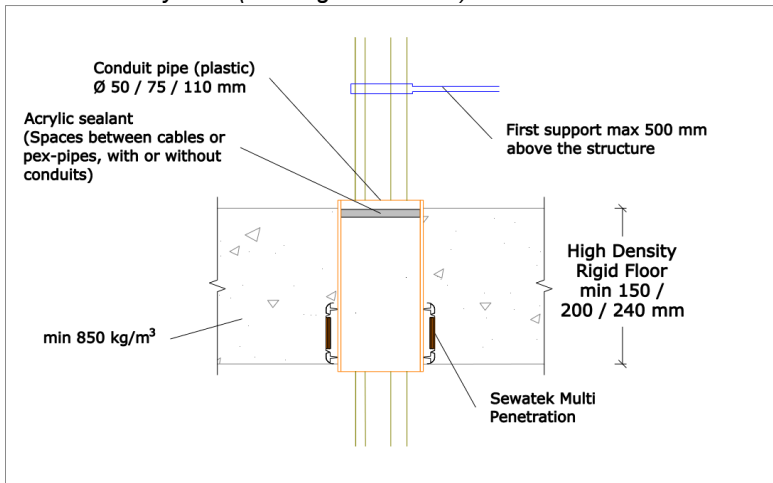

ANNEX 1

Installation way 2c-4 (Casting or drill hole)

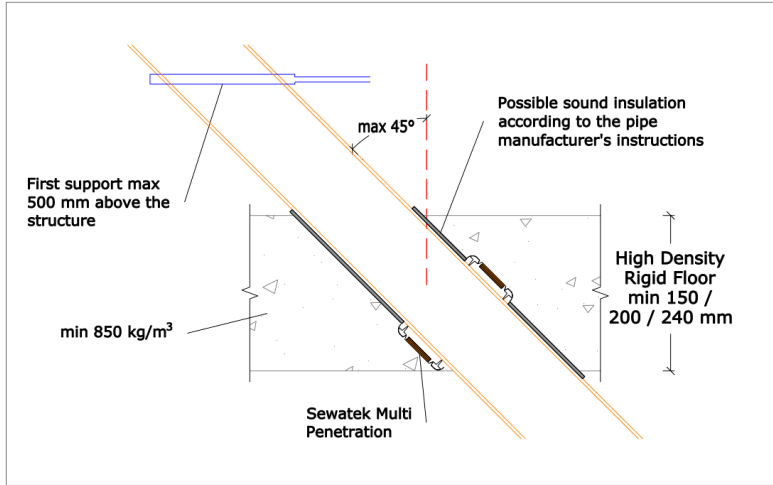

Table 2c. Sewatek Multi Penetration seals D80, D105, and D140 mounted in 150, 200 mm or 240 mm thick High-Density Rigid Floor

Insulation markings (See Annex 2)	Markings (See Annex 3)
<p>LI – Local and Interrupted CI – Continuous and Interrupted CS – Continuous and Sustained sw – Stone wool insulation cr – Cellular rubber insulation</p> <p style="text-align: right;">sw insulation thickness - 20 mm (Pipes < 54 mm) - 30 mm (Pipes ≥ 54 mm)</p>	<p>e_n – Pipe wall thickness a_1 – Thickness of the pipe closure device a_2 – Distance between pipe closure devices</p> <p>When tested as a single, a_2 – distance is 100 mm ("-" in the table)</p>

Type of the pipe	Insulation (thickness / length)	a_2 [mm]	Fire resistance class
<i>Installation in the lower part of the construction – (Installation way 2c-1)</i>			
PP and multilayer sewer pipes			
<i>Mounted into the high-density rigid floor of 150 mm</i>			
<p>$\varnothing \leq 110$ mm, $e_n \leq 6,5$ mm</p> <ul style="list-style-type: none"> • PP-pipes (EN 1451-1) • Geberit: Silent (dB20, Pro, PP) • Pipelife: Master 3+ • Polo-Kal: NG/XS, 3S • Rehau: Raupiano Plus • Uponor: HTP, Decibel • Wavin: AS+, SiTech+ 	not required	28	EI 120 – U/C
<p>$\varnothing \leq 110$ mm, $e_n \leq 6,5$ mm</p> <ul style="list-style-type: none"> • PP-pipes (EN 1451-1) • Geberit: Silent (dB20, Pro, PP) • Pipelife: Master 3+ • Polo-Kal: NG/XS, 3S • Rehau: Raupiano Plus • Uponor: HTP, Decibel • Wavin: AS+, SiTech+ 	CI (sw 30 mm / -)	28	EI 120 – U/U
<p>$\varnothing \leq 110$ mm, $e_n \leq 5,3$ mm</p> <ul style="list-style-type: none"> • PP-pipes (EN 1451-1) • Geberit: Silent (dB20, Pro, PP) • Pipelife: Master 3+ • Polo-Kal: NG/XS, 3S • Rehau: Raupiano Plus • Uponor: HTP, Decibel • Wavin: AS+, SiTech+ 	not required	30	EI 90 – U/U

ANNEX 1

Type of the pipe	Insulation (thickness / length)	a ₂ [mm]	Fire resistance class
Installation on muff OR/AND without plastic cover and gaskets			
Ø ≤ 110 mm, e _n ≤ 13 mm (6,5 + 6,5 mm on muff) <ul style="list-style-type: none"> • PP-pipes (EN 1451-1) • Geberit: Silent (dB20, Pro, PP) • Pipelife: Master 3+ • Polo-Kal: NG/XS, 3S • Rehau: Raupiano Plus • Uponor: HTP, Decibel • Wavin: AS+, SiTech+ 	not required	30	EI 90 – U/U
Cast iron			
Mounted into the high-density rigid floor of 200 mm			
Ø ≤ 110 mm, e _n ≤ 3,5 mm	LI (sw 30 mm / 350 mm)	-	EI 120 - U/C
Steel pipes			
Mounted into the high-density rigid floor of 240 mm			
Ø ≤ 110 mm, e _n ≤ 4,5 mm	CI (sw 30 mm / -)	-	EI 120 - U/C
Composite pipes			
Mounted into the high-density rigid floor of 150 mm			
Ø ≤ 75 mm, e _n ≤ 8,0 mm	CI (sw 30 mm / -)	-	EI 120 - U/C
2x LK PAL Ø 32 (/52) Universal A32	Pre-insulated 10 mm PE	-	EI 120 – U/C
PP and multilayer sewer pipes			
Mounted into the high-density rigid floor of 150 mm			
Installation at a maximum height of 160 mm from the bottom surface - (Installation way 2c-2)			
Ø ≤ 110 mm, e _n ≤ 5,3 mm <ul style="list-style-type: none"> • PP-pipes (EN 1451-1) • Geberit: Silent (dB20, Pro, PP) • Pipelife: Master 3+ • Polo-Kal: NG/XS, 3S • Rehau: Raupiano Plus • Uponor: HTP, Decibel • Wavin: AS+, SiTech+ 	not required	30	EI 120 U/C
Installation in an angle between 90° and 45° - (Installation way 2c-4)			
Ø ≤ 110 mm, e _n ≤ 4,5 mm <ul style="list-style-type: none"> • PP-pipes (EN 1451-1) • Geberit: Silent (dB20, Pro, PP) • Pipelife: Master 3+ • Polo-Kal: NG/XS, 3S • Rehau: Raupiano Plus • Uponor: HTP, Decibel • Wavin: AS+, SiTech+ 	not required	-	EI 120 U/C
Installation in the lower part of the construction with or without conduit – (Installation way 2c-3)			
PEX-pipes			
Mounted into the high-density rigid floor of 150 mm			
PEX bundle Ø ≤ 102 mm - singular PEX Ø ≤ 22/34 mm, e _n ≤ 3,0 mm	not required	30	EI 120 – U/C
Cables			
Mounted into high-density rigid floor of 150 mm			
Cable Ø ≤ 25 mm	not required	-	EI 90
Cable Ø ≤ 22 mm	not required	30	EI 90
Cable bundle Ø ≤ 100 mm - singular cable Ø ≤ 22 mm	not required	30	EI 90
Cable conduit Ø 110 mm (plastic) - cable bundle Ø ≤ 100 mm - singular cable Ø ≤ 25 mm	not required	-	EI 90

High-Density Rigid Floor

2d - Sewatek Fire Wrap

Installation way 2d-1 (Casting or drill hole)

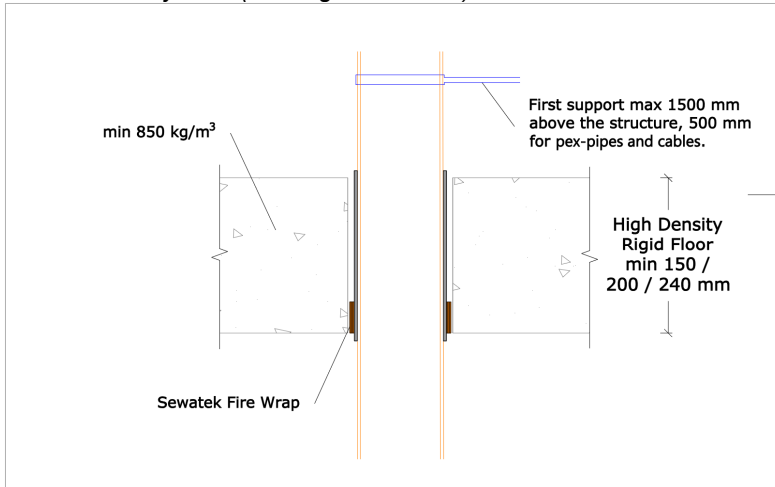

Fire Wrap	a ₁ (mm)
W 50	7
W 75	7
W 110	7
W 160	12

Installation way 2d-2 (Casting or drill hole)

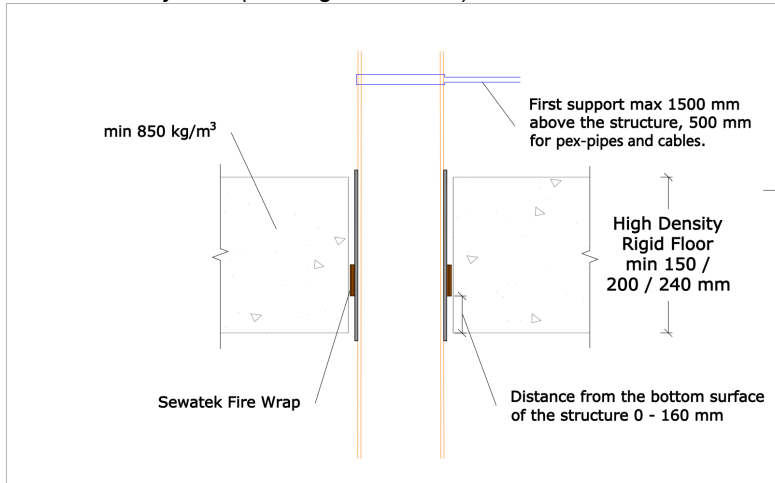

Installation way 2d-3 (Casting or drill hole)

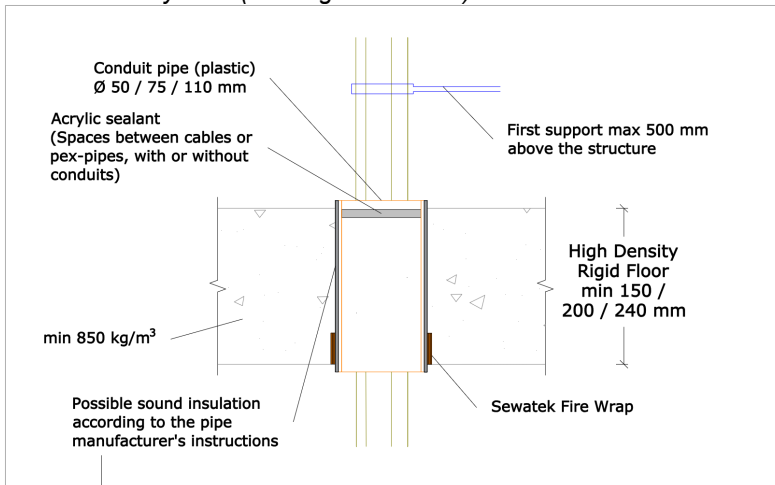

ANNEX 1

Installation way 2d-4 (Casting or drill hole)

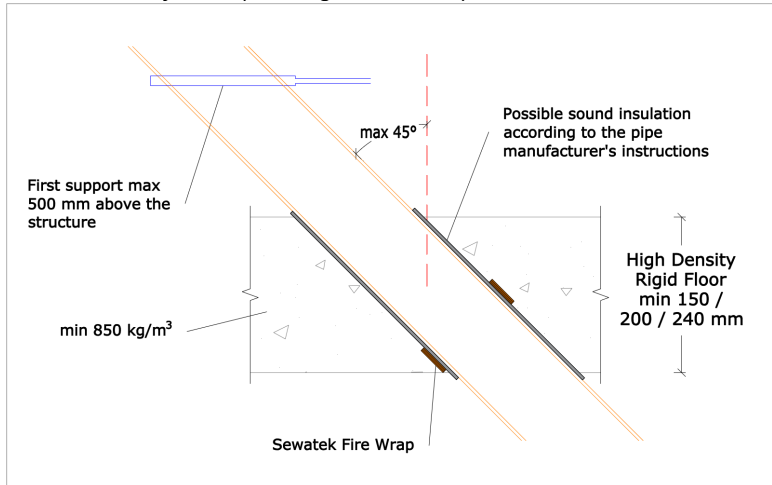

Table 2d. Sewatek Fire Wrap mounted in 150, 200 mm or 240 mm thick High-Density Rigid Floor

Insulation markings (See Annex 2)	Markings (See Annex 3)
<p>LI – Local and Interrupted CI – Continuous and Interrupted CS – Continuous and Sustained sw – Stone wool insulation cr – Cellular rubber insulation</p>	<p>e_n – Pipe wall thickness a_1 – Thickness of the pipe closure device a_2 – Distance between pipe closure devices When tested as a single, a_2 – distance is 100 mm ("-" in the table)</p>
<p>sw insulation thickness - 20 mm (Pipes < 54 mm) - 30 mm (Pipes \geq 54 mm)</p>	

Type of the pipe	Insulation (thickness / length)	a ₂ [mm]	Fire resistance class
<i>Installation in the lower part of the construction – (Installation way 2d-1)</i>			
PP and multilayer sewer pipes			
Mounted into the high-density rigid floor of 150 mm			
<p>$\varnothing \leq 160$ mm, $e_n \leq 7,5$ mm</p> <ul style="list-style-type: none"> • PP-pipes (EN 1451-1) • Geberit: Silent (dB20, Pro, PP) • Pipelife: Master 3+ • Polo-Kal: NG/XS, 3S • Rehau: Raupiano Plus • Uponor: HTP, Decibel • Wavin: AS+, SiTech+ 	CI (sw 40 mm / -)	-	EI 60 – U/U
<p>$\varnothing \leq 110$ mm, $e_n \leq 6,5$ mm</p> <ul style="list-style-type: none"> • PP-pipes (EN 1451-1) • Geberit: Silent (dB20, Pro, PP) • Pipelife: Master 3+ • Polo-Kal: NG/XS, 3S • Rehau: Raupiano Plus • Uponor: HTP, Decibel • Wavin: AS+, SiTech+ 	not required	28	EI 120 – U/C
<p>$\varnothing \leq 110$ mm, $e_n \leq 6,5$ mm</p> <ul style="list-style-type: none"> • PP-pipes (EN 1451-1) • Geberit: Silent (dB20, Pro, PP) • Pipelife: Master 3+ • Polo-Kal: NG/XS, 3S • Rehau: Raupiano Plus • Uponor: HTP, Decibel • Wavin: AS+, SiTech+ 	CI (sw 30 mm / -)	28	EI 120 – U/U

ANNEX 1

Type of the pipe	Insulation (thickness / length)	a ₂ [mm]	Fire resistance class
$\varnothing \leq 110$ mm, e _n ≤ 13 mm (6,5 + 6,5 mm on muff) • PP-pipes (EN 1451-1) • Geberit : Silent (dB20, Pro, PP) • Pipelife : Master 3+ • Polo-Kal : NG/XS, 3S • Rehau : Raupiano Plus • Uponor : HTP, Decibel • Wavin : AS+, SiTech+	not required	30	EI 90 – U/U
<i>Installation at a maximum height of 160 mm from the bottom surface - (Installation way 2d-2)</i>			
$\varnothing \leq 110$ mm, e _n ≤ 5,3 mm • PP-pipes (EN 1451-1) • Geberit : Silent (dB20, Pro, PP) • Pipelife : Master 3+ • Polo-Kal : NG/XS, 3S • Rehau : Raupiano Plus • Uponor : HTP, Decibel • Wavin : AS+, SiTech+	not required	15 / 30	EI 120 U/C
<i>Installation in an angle between 90° and 45° - (Installation way 2d-4)</i>			
$\varnothing \leq 110$ mm, e _n ≤ 4,5 mm • PP-pipes (EN 1451-1) • Geberit : Silent (dB20, Pro, PP) • Pipelife : Master 3+ • Polo-Kal : NG/XS, 3S • Rehau : Raupiano Plus • Uponor : HTP, Decibel • Wavin : AS+, SiTech+	not required	-	EI 120 U/C
<i>Installation in the lower part of the construction – (Installation way 2d-1)</i>			
Cast iron			
<i>Mounted into the high-density rigid floor of 200 mm</i>			
$\varnothing \leq 110$ mm, e _n ≤ 3,5 mm	LI (sw 30 mm / 350 mm)	-	EI 120 - U/C
Steel pipes			
<i>Mounted into the high-density rigid floor of 240 mm</i>			
$\varnothing \leq 110$ mm, e _n ≤ 4,5 mm	CI (sw 30 mm / -)	-	EI 120 - U/C
Composite pipes			
<i>Mounted into the high-density rigid floor of 150 mm</i>			
$\varnothing \leq 75$ mm, e _n ≤ 8,0 mm	CI (sw 30 mm / -)	-	EI 120 - U/C
2x LK PAL Ø32 (/52) Universal A32	Pre-insulated 10 mm PE	-	EI 120 – U/C
<i>Installation in the lower part of the structure with or without conduit – (Installation way 2c-3)</i>			
PEX-pipes			
<i>Mounted into the high-density rigid floor of 150 mm</i>			
PEX bundle $\varnothing \leq 102$ mm - singular PEX $\varnothing \leq 22/34$ mm, e _n ≤ 3,0 mm	not required	30	EI 120 – U/C
Cables			
<i>Mounted into high-density rigid floor of 150 mm</i>			
Cable $\varnothing \leq 25$ mm	not required	-	EI 90
Cable $\varnothing \leq 22$ mm	not required	30	EI 90
Cable bundle $\varnothing \leq 100$ mm - singular cable $\varnothing \leq 22$ mm	not required	30	EI 90
Cable conduit $\varnothing 110$ mm (plastic) - cable bundle $\varnothing \leq 100$ mm - singular cable $\varnothing \leq 25$ mm	not required	-	EI 90

Massive Wood (CLT or LVL) Wall

3a - Sewatek Fire Collars

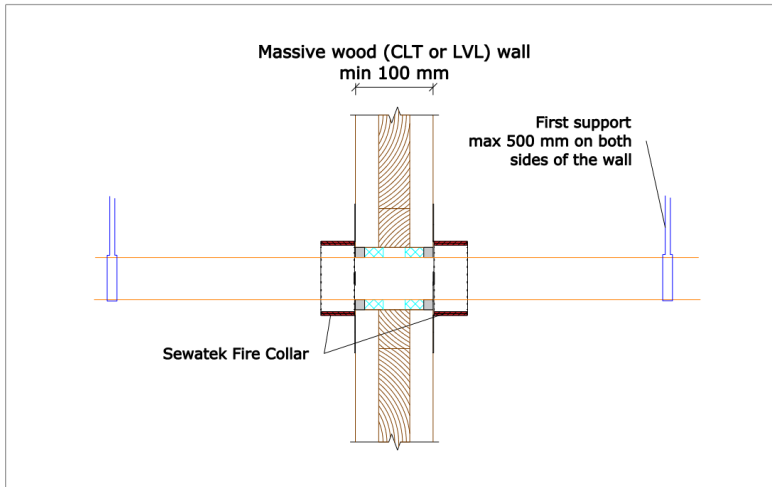

Fire Collar	a ₁ (mm)
C 16-32	5
C 25-50	5
C 50-80	7
C 75-110	7
C 110-130	7
C 125-160	12

Table 3a. Sewatek Fire Collars mounted in 100 mm massive wood (CLT or LVL) wall

Insulation markings (See Annex 2)	Markings (See Annex 3)
LI – Local and Interrupted CI – Continuous and Interrupted CS – Continuous and Sustained sw – Stone wool insulation cr – Cellular rubber insulation	e _n – Pipe wall thickness a ₁ – Thickness of the pipe closure device a ₂ – Distance between pipe closure devices When tested as a single, a ₂ -distance is 100 mm ("-" in the table)
sw insulation thickness - 20 mm (Pipes < 54 mm) - 30 mm (Pipes ≥ 54 mm)	

Type of the pipe	Penetration seal	Insulation (thickness / length)	a ₂ [mm]	Fire resistance class
Composite pipes				
∅ ≤ 75 mm, e _n ≤ 8 mm	C 50-80	CI (sw 30 mm / -)	-	EI 60 - U/C
PP, PVC and multilayer sewer pipes				
∅ ≤ 110, e _n ≤ 6,5 mm • PP-pipes (EN 1451-1) • Geberit: Silent (dB20, Pro, PP) • Pipelife: Master 3+ • Polo-Kal: NG/XS, 3S • Rehau: Raupiano Plus • Uponor: HTP, Decibel • Wavin: AS+, SiTech+	C 75-110	not required	-	EI 60 - U/C
∅ ≤ 110 mm, e _n ≤ 4,2 mm • PP-pipes (EN 1451-1) • Geberit: Silent (dB20, Pro, PP) • Pipelife: Master 3+ • Polo-Kal: NG/XS, 3S • Rehau: Raupiano Plus • Uponor: HTP, Decibel • Wavin: AS+, SiTech+	C 75-110	not required	60	EI 60 - U/C
PVC (EN 13476) ∅ ≤ 110 mm, e _n ≤ 3,4 mm	C 75-110	not required	30	EI 90 U/C

ANNEX 1

Type of the pipe	Penetration seal	Insulation (thickness / length)	a ₂ [mm]	Fire resistance class
Sewer pipes with lining				
PVC Ø ≤ 110 mm, e _n ≤ 3,4 mm + lining (Boldan, Brawoliner, Trelleborg)	C 75-110	not required	30	EI 90 – U/C
PP Ø ≤ 110 mm, e _n ≤ 3,4 mm + lining (Boldan, Brawoliner, Trelleborg)	C 75-110	not required	30	EI 90 – U/C

Massive Wood (CLT, LVL) Wall

3b - Sewatek Multi Penetration

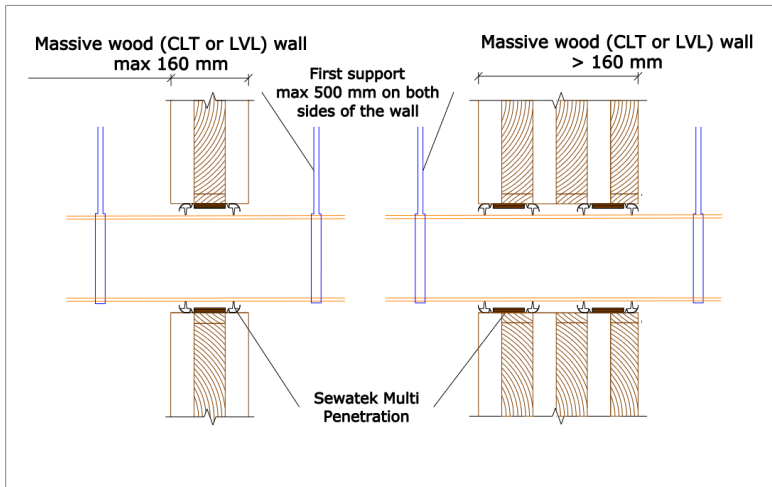

Multi	Max penetrating pipe / bundle	a ₁ (mm)
D80	50	15
D105	75	15
D140	110	15

Table 3b. Sewatek Multi Penetration seals D80, D105, D140 mounted in **100 mm thick massive wood (CLT or LVL) wall**

Insulation markings (See Annex 2)	Markings (See Annex 3)
LI – Local and Interrupted CI – Continuous and Interrupted CS – Continuous and Sustained sw – Stone wool insulation cr – Cellular rubber insulation	e _n – Pipe wall thickness a ₁ – Thickness of the pipe closure device a ₂ – Distance between pipe closure devices When tested as a single, a ₂ – distance is 100 mm ("-" in the table)
sw insulation thickness - 20 mm (Pipes < 54 mm) - 30 mm (Pipes ≥ 54 mm)	

Type of the pipe	Insulation	a ₂ [mm]	Fire resistance class
PP and multilayer sewer pipes			
Ø ≤ 110 mm, e _n ≤ 6,0 mm • PP-pipes (EN 1451-1) • Geberit : Silent (dB20, Pro, PP) • Pipelife : Master 3+ • Polo-Kal : NG/XS, 3S • Rehau : Raupiano Plus • Uponor : HTP, Decibel • Wavin : AS+, SiTech+	not required	30	EI 60 U/C
PEX-pipes			
Pex bundle Ø ≤ 100 mm - singular pipe Ø ≤ 40/54 mm, e _n ≤ 2,5 - 4,2 mm	not required	-	EI 90 U/C
Cables			
Singular cable Ø ≤ 22 mm	not required	-	EI 60
Cable bundle Ø ≤ 100 mm - singular cable Ø ≤ 22 mm	not required	-	EI 60

Massive Wood (CLT, LVL) Wall

3c - Sewatek Fire Wrap

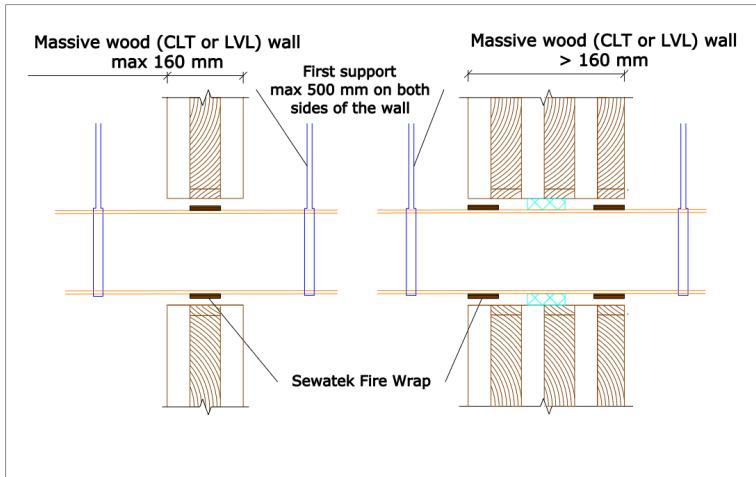

Fire Wrap	a ₁ (mm)
W 50	7
W 75	7
W 110	7

Table 3c. Sewatek Fire Wrap mounted in 100 mm massive wood (CLT or LVL) wall	
Insulation markings (See Annex 2)	Markings (See Annex 3)
LI – Local and Interrupted CI – Continuous and Interrupted CS – Continuous and Sustained sw – Stone wool insulation cr – Cellular rubber insulation	e _n – Pipe wall thickness a ₁ – Thickness of the pipe closure device a ₂ – Distance between pipe closure devices When tested as a single, a ₂ -distance is 100 mm ("-" in the table)
sw insulation thickness	
- 20 mm (Pipes < 54 mm)	
- 30 mm (Pipes ≥ 54 mm)	

** Sewatek fire wrap on both sides of the wall

Type of the pipe	Insulation	a ₂ [mm]	Fire resistance class
PP and multilayer sewer pipes			
<i>Mounted into the massive wood wall (CLT or LVL) of 100 mm</i>			
Ø ≤ 110 mm, e _n ≤ 10,6 mm (on muff 5,3 + 5,3 mm) ** • PP-pipes (EN 1451-1) • Geberit: Silent (dB20, Pro, PP) • Pipelife: Master 3+ • Polo-Kal: NG/XS, 3S • Rehau: Raupiano Plus • Uponor: HTP, Decibel • Wavin: AS+, SiTech+	not required	-	EI 90 U/C
Ø ≤ 110, e _n ≤ 6,0 mm • PP-pipes (EN 1451-1) • Geberit: Silent (dB20, Pro, PP) • Pipelife: Master 3+ • Polo-Kal: NG/XS, 3S • Rehau: Raupiano Plus • Uponor: HTP, Decibel • Wavin: AS+, SiTech+	not required	30	EI 60 U/C
PEX-pipes			
Pex bundle Ø ≤ 100 mm - singular pipe Ø ≤ 40/54 mm, e _n ≤ 2,5 - 4,2 mm	not required	-	EI 90 U/C
Cables			
Singular cable Ø ≤ 22 mm	not required	-	EI 60
Cable bundle Ø ≤ 100 mm - singular cable Ø ≤ 22 mm	not required	-	EI 60

Massive Wood Floor

4a - Sewatek Multi Penetration

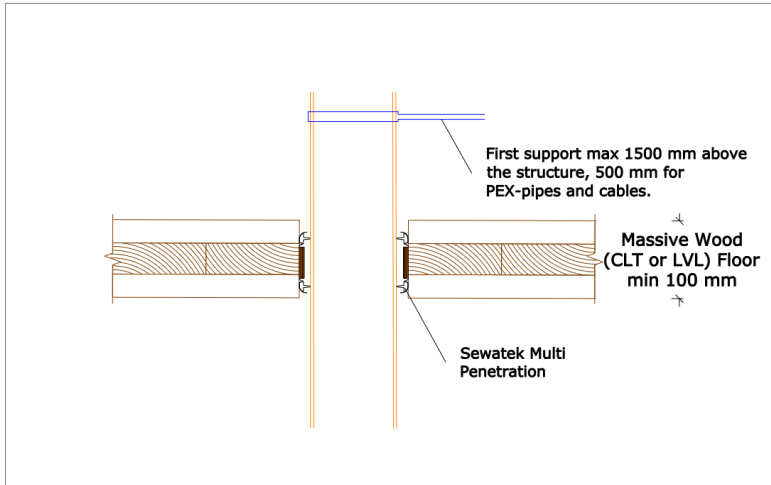

Multi	Max penetrating pipe / bundle	a ₁ (mm)
D80	50	15
D105	75	15
D140	110	15

Table 4a. Sewatek Multi Penetration seals D80, D105, D140 mounted in **100 mm thick massive wood (CLT or LVL) floor**

Insulation markings (See Annex 2)	Markings (See Annex 3)
LI – Local and Interrupted CI – Continuous and Interrupted CS – Continuous and Sustained sw – Stone wool insulation cr – Cellular rubber insulation	e _n – Pipe wall thickness a ₁ – Thickness of the pipe closure device a ₂ – Distance between pipe closure devices When tested as a single, a ₂ – distance is 100 mm ("-" in the table)
sw insulation thickness - 20 mm (Pipes < 54 mm) - 30 mm (Pipes ≥ 54 mm)	

Type of the pipe	Insulation	a ₂ [mm]	Fire resistance class
PP and multilayer sewer pipes			
Ø ≤ 110 mm, e _n ≤ 6,5 mm • PP (EN 1451-1) • Geberit: Silent (dB20, Pro, PP) • Pipelife: Master 3+ • Polo-Kal: NG/XS, 3S • Rehau: Raupiano Plus • Uponor: HTP, Decibel • Wavin: AS+, SiTech+	not required	30	EI 90 U/C
Cables			
Cable Ø ≤ 22 mm	not required	30	EI 60
Cable conduit Ø ≤ 75 mm (plastic) - cable bundle Ø ≤ 66 mm - singular cable Ø ≤ 22 mm	not required	30	EI 60

Massive Wood Floor

4b - Sewatek Fire Wrap

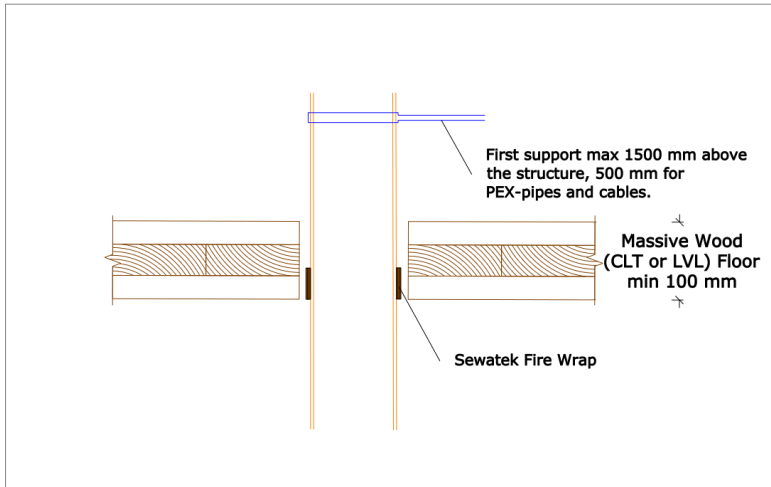

Fire Wrap	a ₁ (mm)
W 50	7
W 75	7
W 110	7

Table 4b. Sewatek Fire Wrap mounted in **100 mm thick massive wood (CLT or LVL) floor**

Insulation markings (See Annex 2)	Markings (See Annex 3)
LI – Local and Interrupted CI – Continuous and Interrupted CS – Continuous and Sustained sw – Stone wool insulation cr – Cellular rubber insulation	e _n – Pipe wall thickness a ₁ – Thickness of the pipe closure device a ₂ – Distance between pipe closure devices When tested as a single, a ₂ -distance is 100 mm ("-" in the table)
sw insulation thickness - 20 mm (Pipes < 54 mm) - 30 mm (Pipes ≥ 54 mm)	

Type of the pipe	Insulation	a ₂ [mm]	Fire resistance class
PP and multilayer sewer pipes			
Ø ≤ 110 mm, e _n ≤ 6,5 mm • PP (EN 1451-1) • Geberit : Silent (dB20, Pro, PP) • Pipelife : Master 3+ • Polo-Kal : NG/XS, 3S • Rehau : Raupiano Plus • Uponor : HTP, Decibel • Wavin : AS+, SiTech+	not required	30	EI 90 U/C
Cables			
Cable Ø ≤ 22 mm	not required	30	EI 60
Cable conduit Ø ≤ 75 mm (plastic) - cable bundle Ø ≤ 66 mm - singular cable Ø ≤ 22 mm	not required	30	EI 60

Flexible Wall

5a - Sewatek Fire Collars

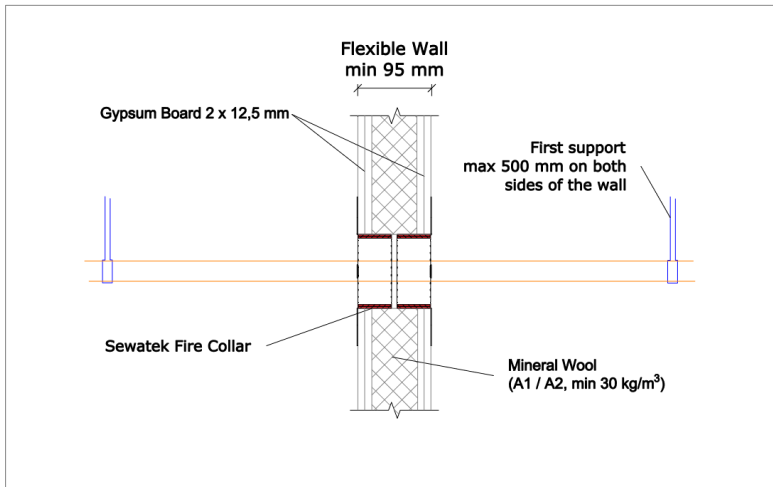

Fire Collar	a ₁ (mm)
C 16-32	5
C 25-50	5
C 50-80	7
C 75-110	7
C 110-130	7
C 125-160	12

Table 5a. Sewatek Fire Collars mounted in **95 mm thick flexible wall**

Insulation markings (See Annex 2)	Markings (See Annex 3)
LI – Local and Interrupted CI – Continuous and Interrupted CS – Continuous and Sustained sw – Stone wool insulation cr – Cellular rubber insulation	e _n – Pipe wall thickness a ₁ – Thickness of the pipe closure device a ₂ – Distance between pipe closure devices When tested as a single, a ₂ -distance is 100 mm ("-" in the table)
sw insulation thickness - 20 mm (Pipes < 54 mm) - 30 mm (Pipes ≥ 54 mm)	

Type of the pipe e _n = pipe wall thickness	Penetration seal	Insulation (thickness / length)	a ₂ [mm]	Fire resistance class
Mounted in flexible wall of 95 mm				
Composite pipes				
Ø ≤ 75 mm, e _n ≤ 8 mm	C 50-80	CI (sw 30 mm / -)	-	EI 60 - U/C
PP, PVC and multilayer sewer pipes				
Ø ≤ 110 mm, e _n ≤ 6,5 mm • PP (EN 1451-1) • Geberit: Silent (dB20, Pro, PP) • Pipelife: Master 3+ • Polo-Kal: NG/XS, 3S • Rehau: Raupiano Plus • Uponor: HTP, Decibel • Wavin: AS+, SiTech+	C 75-110	not required	-	EI 60 - U/C
PP (EN 1451-1) Ø ≤ 110 mm, e _n ≤ 3,4 mm	C 75-110	not required	30	EI 90 U/C
PVC (EN 13476) Ø ≤ 110 mm, e _n ≤ 3,4 mm	C 75-110	not required	30	EI 90 U/C
Sewer pipes with lining				
PVC (EN 13476) Ø ≤ 110 mm, e _n ≤ 3,4 mm + lining (Boldan, Brawoliner, Trelleborg)	C 75-110	not required	30	EI 90 – U/C
PP (EN 1451-1) Ø ≤ 110 mm, e _n ≤ 3,4 mm + lining (Boldan, Brawoliner, Trelleborg)	C 75-110	not required	30	EI 90 – U/C

Flexible Wall

5b - Sewatek Multi Penetration seals

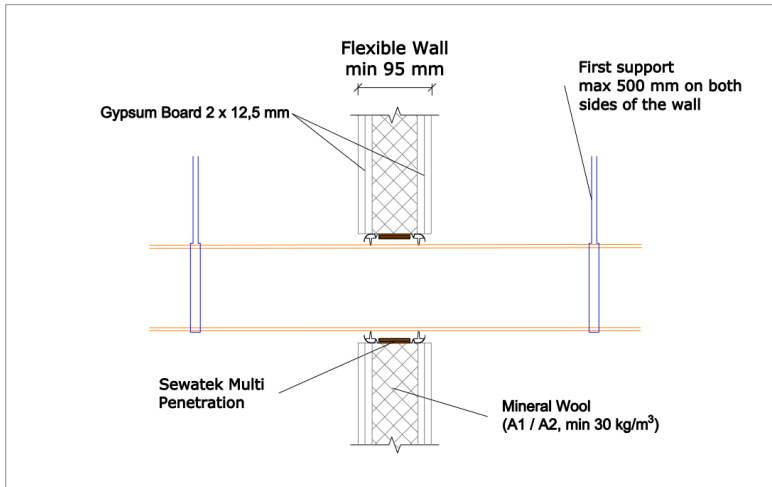

Multi	Max penetrating pipe / bundle	a ₁ (mm)
D80	50	15
D105	75	15
D140	110	15

Table 5b. Sewatek Multi Penetration seals D80, D105, D140 mounted in **95 mm thick flexible wall**

Insulation markings (See Annex 2)	Markings (See Annex 3)
LI – Local and Interrupted CI – Continuous and Interrupted CS – Continuous and Sustained sw – Stone wool insulation cr – Cellular rubber insulation	e _n – Pipe wall thickness a ₁ – Thickness of the pipe closure device a ₂ – Distance between pipe closure devices When tested as a single, a ₂ -distance is 100 mm ("-" in the table)
sw insulation thickness - 20 mm (Pipes < 54 mm) - 30 mm (Pipes ≥ 54 mm)	

Type of the pipe	Insulation	a ₂ [mm]	Fire resistance class
PP pipes			
Ø ≤ 110 mm, e _n ≤ 6,0 mm • PP (EN 1451-1) • Geberit: Silent (dB20, Pro, PP) • Pipelife: Master 3+ • Polo-Kal: NG/XS, 3S • Rehau: Raupiano Plus • Uponor: HTP, Decibel • Wavin: AS+, SiTech+	not required	30	EI 60 U/C
PEX-pipes			
Pex bundle Ø ≤ 100 mm - singular pipe Ø ≤ 40/54 mm, e _n ≤ 2,5 - 4,2 mm	not required	-	EI 90 U/C
Cables			
Singular cable Ø ≤ 22 mm	not required	-	EI 60
Cable bundle Ø ≤ 100 mm - singular cable Ø ≤ 22 mm	not required	-	EI 60

Flexible Wall

5c - Sewatek Fire Wrap

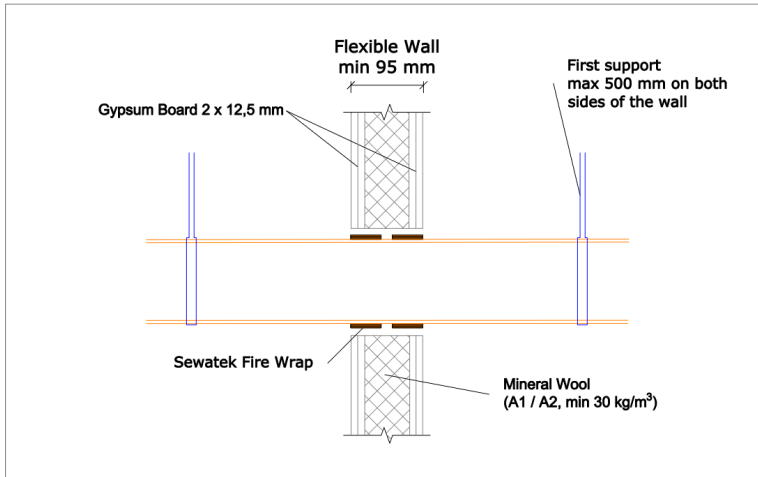

Fire Wrap	a ₁ (mm)
W 50	7
W 75	7
W 110	7

Table 5c. Sewatek Fire Wrap mounted in 95 mm flexible wall	
Insulation markings (See Annex 2)	Markings (See Annex 3)
LI – Local and Interrupted CI – Continuous and Interrupted CS – Continuous and Sustained sw – Stone wool insulation cr – Cellular rubber insulation	e _n – Pipe wall thickness a ₁ – Thickness of the pipe closure device a ₂ – Distance between pipe closure devices When tested as a single, a ₂ – distance is 100 mm ("-" in the table)
sw insulation thickness	
- 20 mm (Pipes < 54 mm)	
- 30 mm (Pipes ≥ 54 mm)	

Type of the pipe	Insulation	a ₂ [mm]	Fire resistance class
PP and multilayer sewer pipes			
Ø ≤ 110, e _n ≤ 10,6 mm (on muff 5,3 + 5,3 mm) • PP (EN 1451-1) • Geberit: Silent (dB20, Pro, PP) • Pipelife: Master 3+ • Polo-Kal: NG/XS, 3S • Rehau: Raupiano Plus • Uponor: HTP, Decibel • Wavin: AS+, SiTech+	not required	-	EI 120 U/C
Ø ≤ 110, e _n ≤ 6,0 mm • PP (EN 1451-1) • Geberit: Silent (dB20, Pro, PP) • Pipelife: Master 3+ • Polo-Kal: NG/XS, 3S • Rehau: Raupiano Plus • Uponor: HTP, Decibel • Wavin: AS+, SiTech+	not required	30	EI 60 U/C
PEX-pipes			
Pex bundle Ø ≤ 100 mm - singular pipe Ø ≤ 40/54 mm, e _n ≤ 2,5 - 4,2 mm	not required	-	EI 90 U/C
Cables			
Singular cable Ø ≤ 22 mm	not required	-	EI 60
Cable bundle Ø ≤ 100 mm - singular cable Ø ≤ 22 mm	not required	-	EI 60

Annex 2 – Insulation

Wall structure

LI – Local and Interrupted

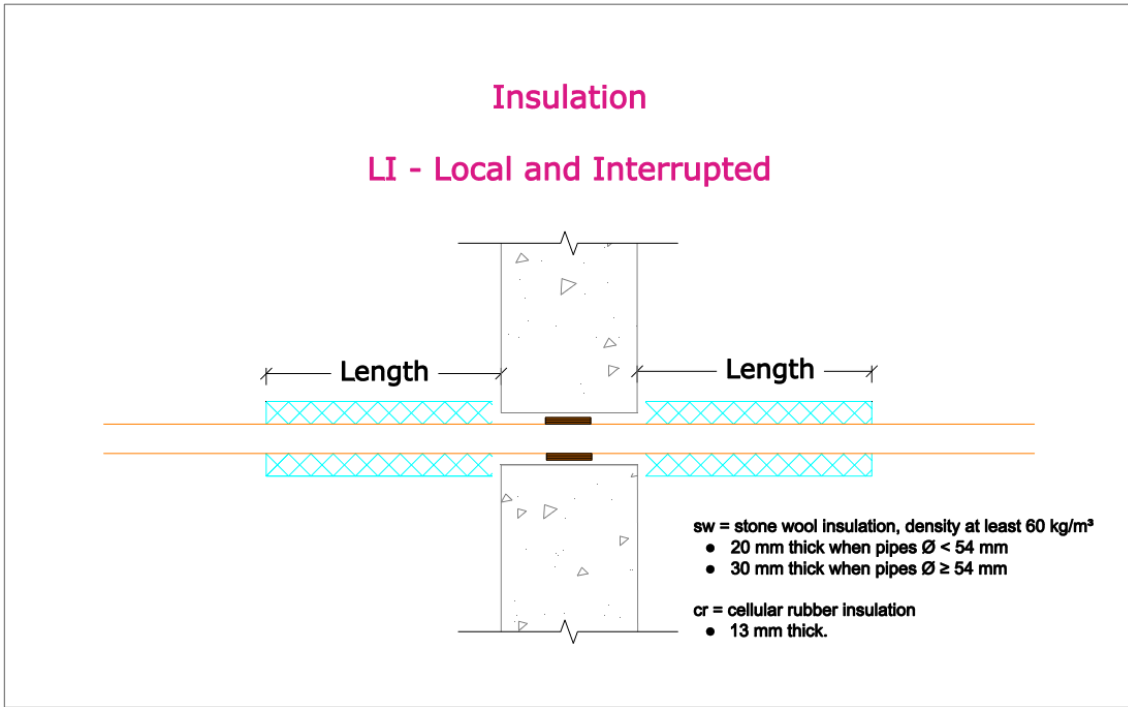

LS – Local and Sustained

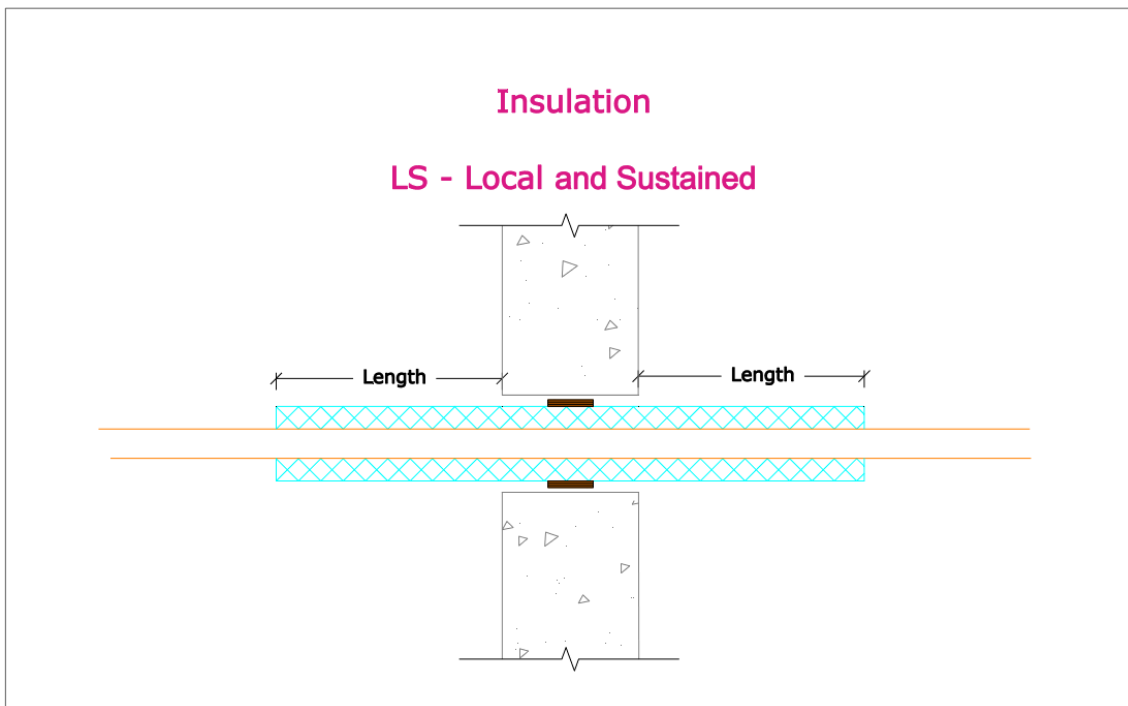

CI – Continuous and Interrupted

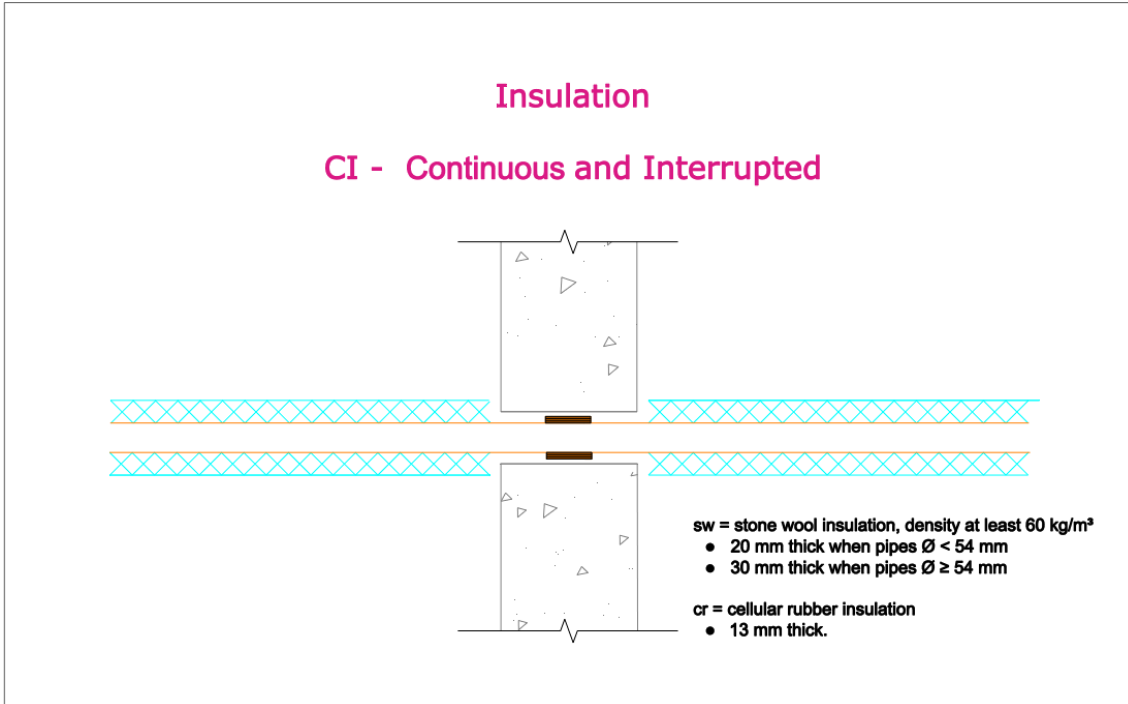

CS – Continuous and Sustained

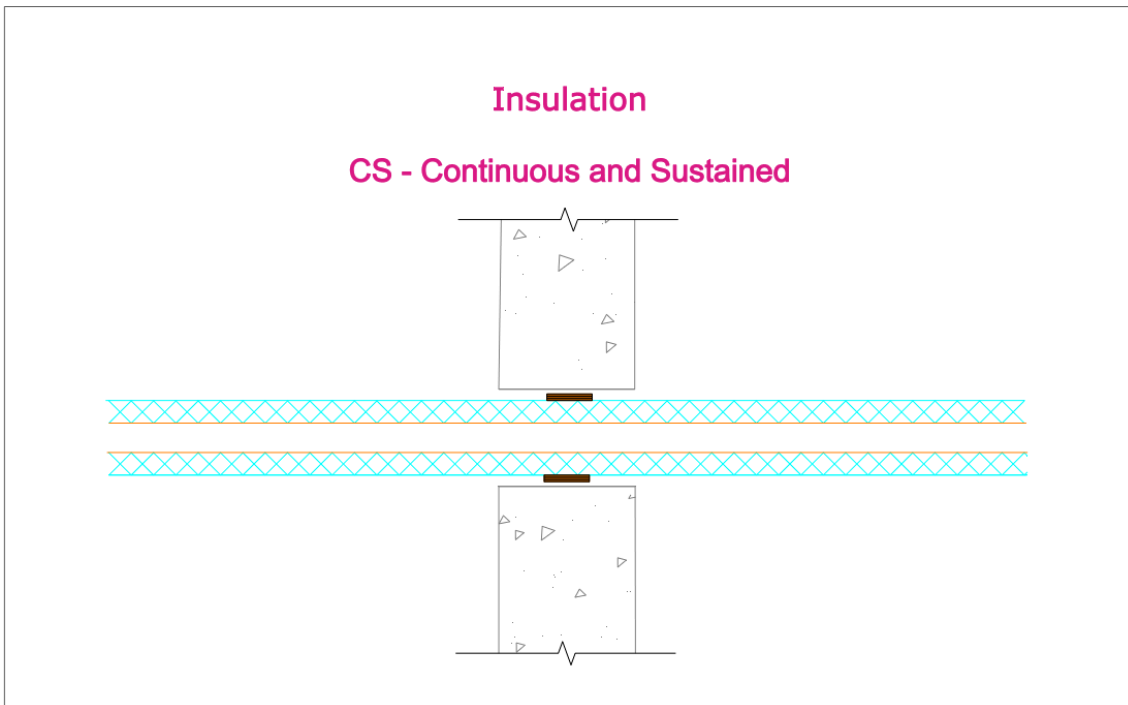

Floor structure

LI – Local and Interrupted

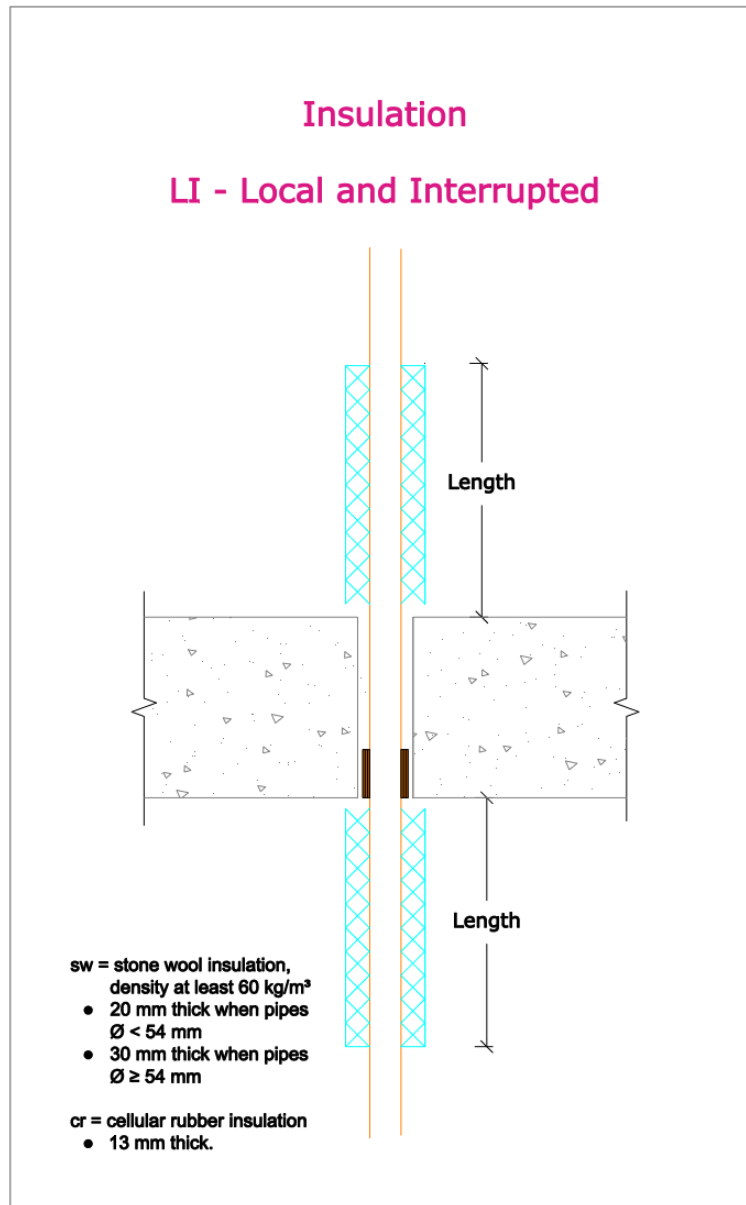

LS – Local and Sustained

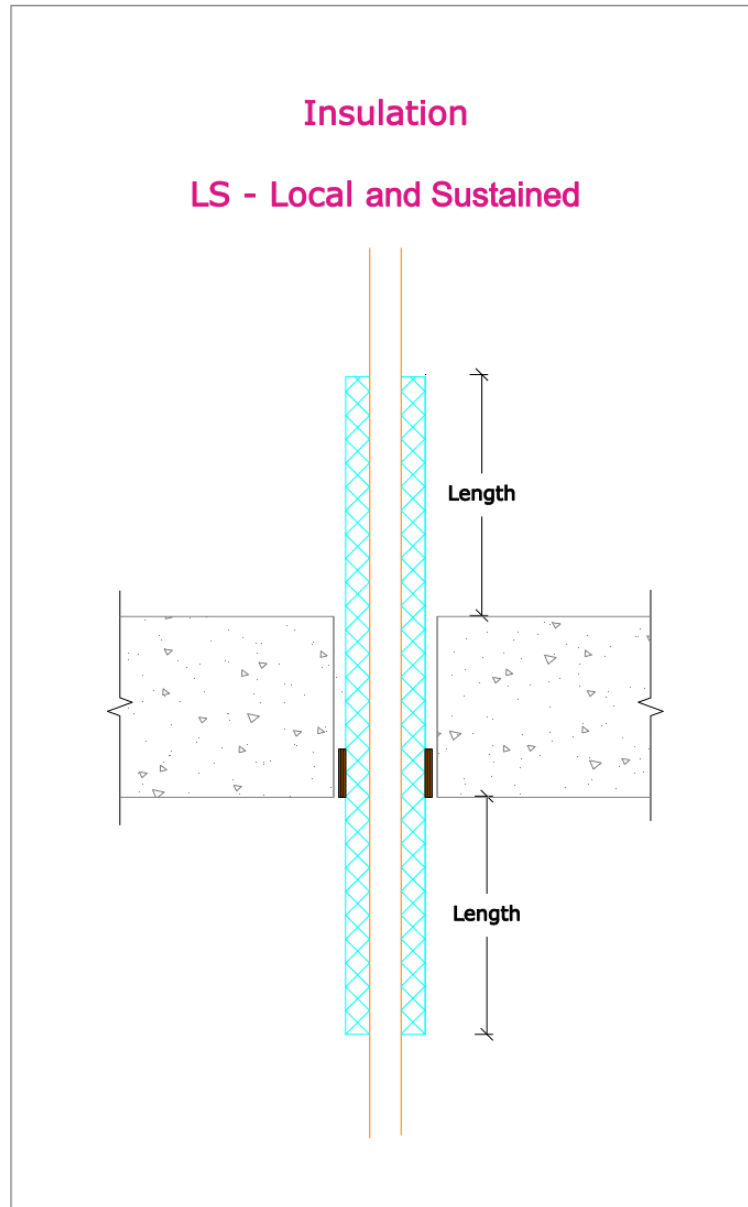

CI – Continuous and Interrupted

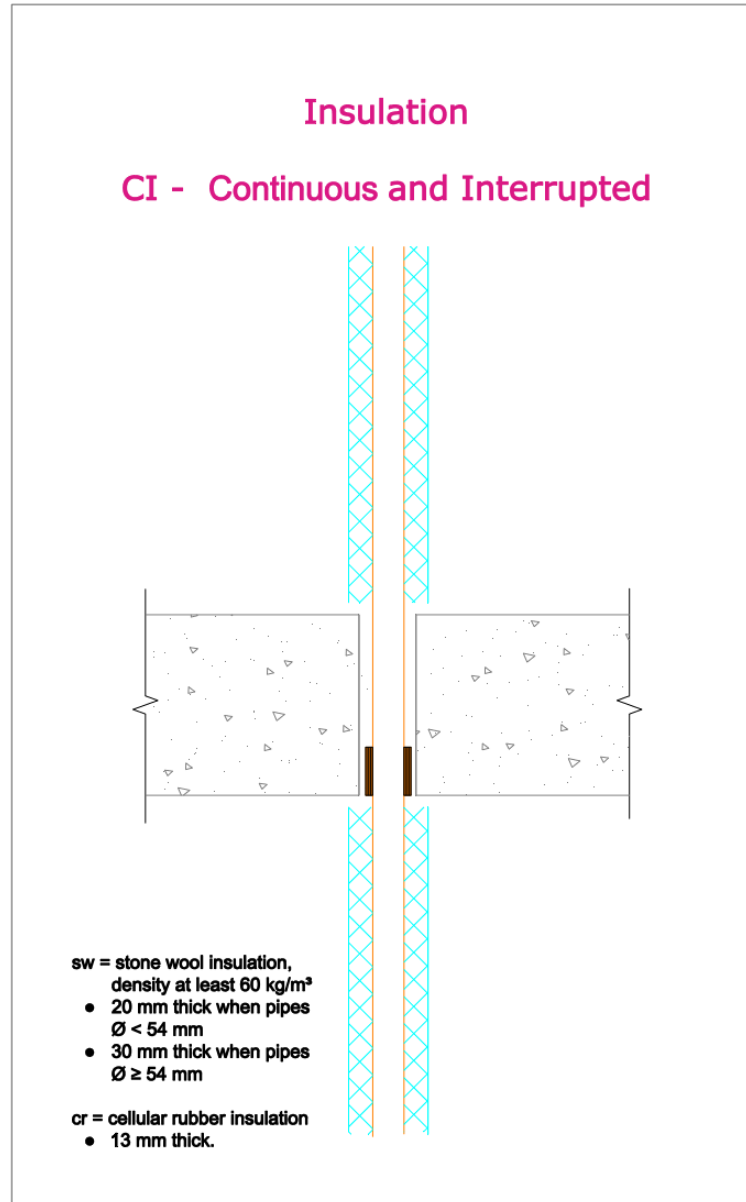

CS – Continuous and Sustained

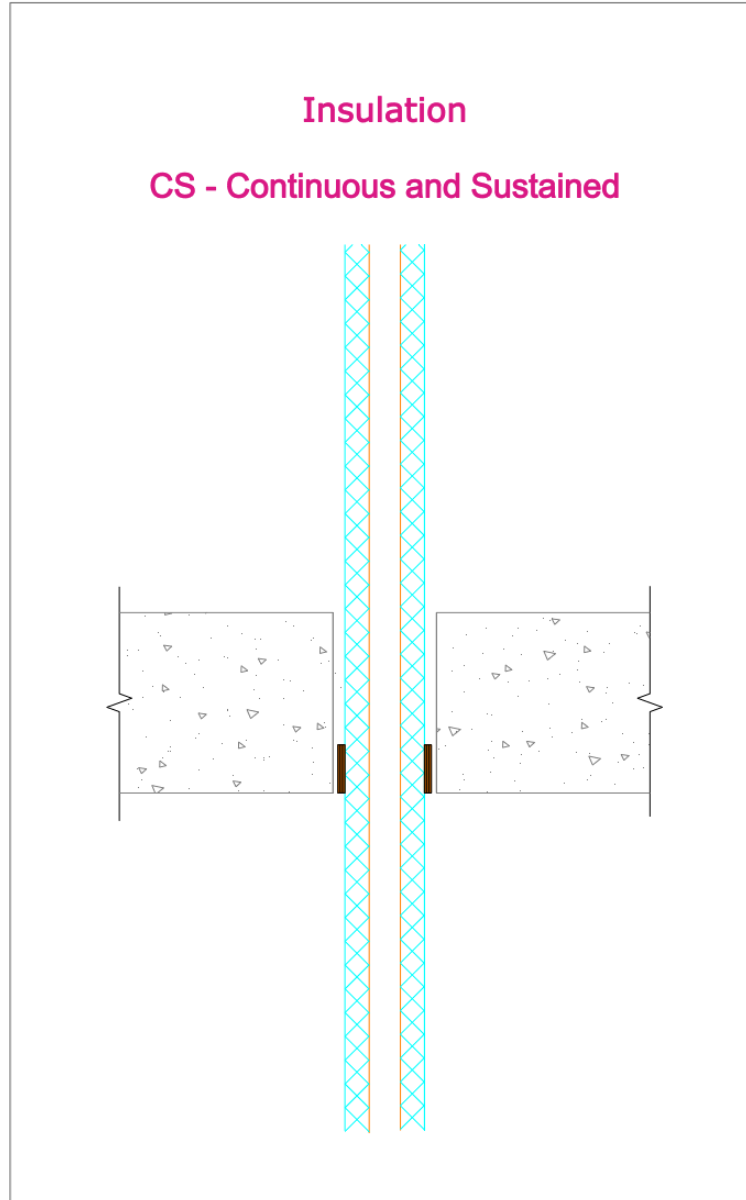

Annex 3 – The principle of measurement

Cluster Layout

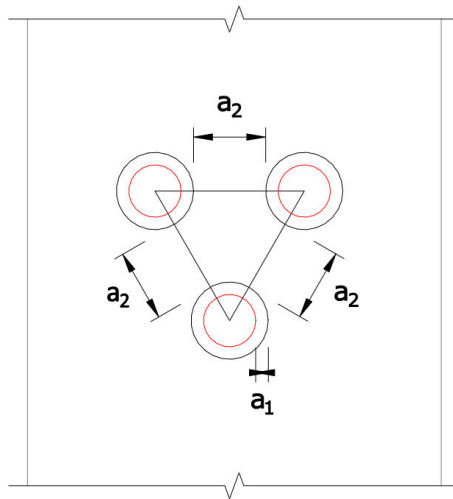

- a_1 Thickness of the pipe closure device
- a_2 Distance between pipe closure devices



In-Line Layout

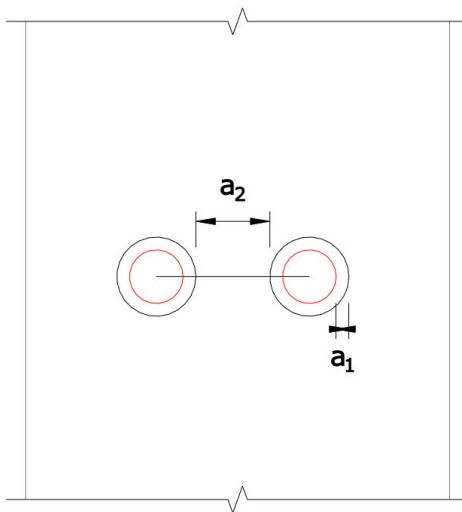

- a_1 Thickness of the pipe closure device
- a_2 Distance between pipe closure devices

